

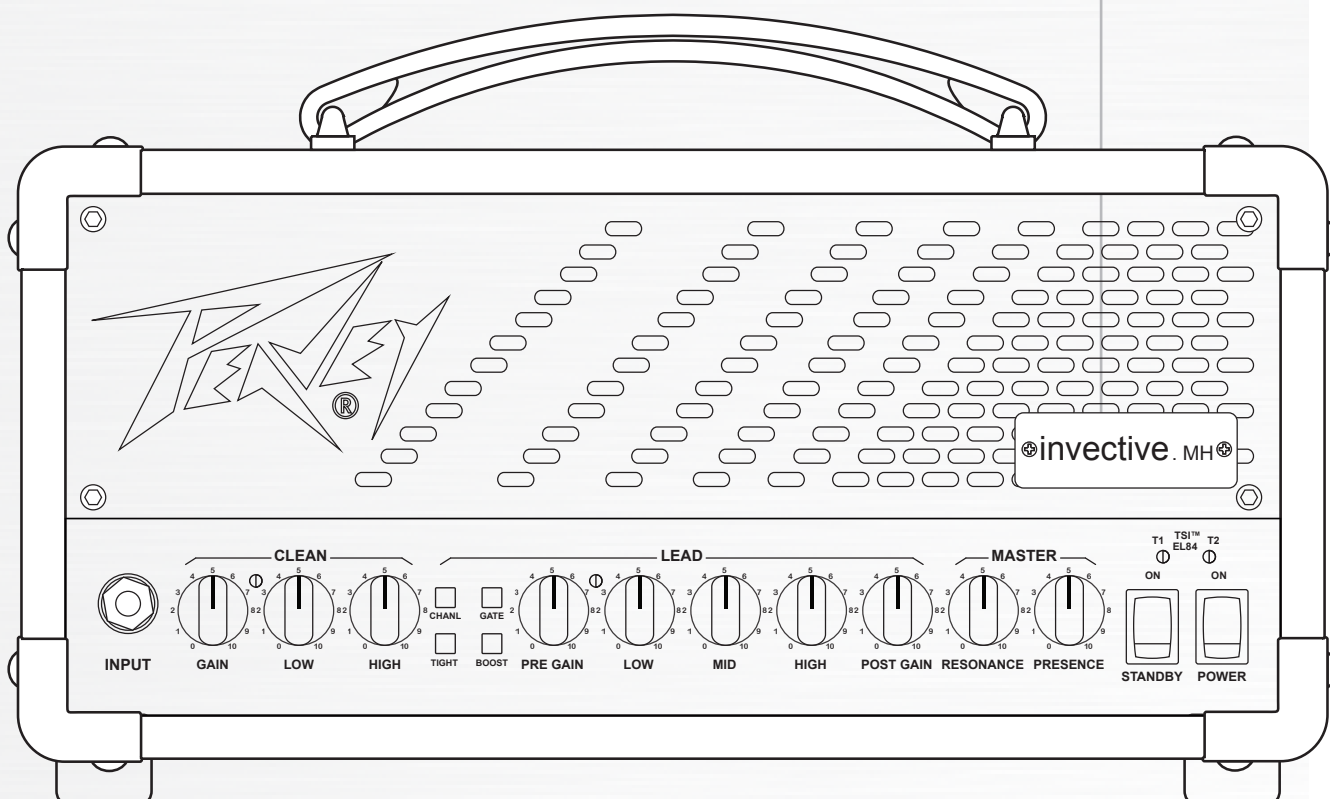

# Peavey® Invective® MH 20W Tube Guitar Amplifier

Operating  
Manual





## FCC/ICES Compliancy Statement

This device complies with Part 15 of the FCC rules and Industry Canada license-exempt RSS Standard(s). Operation is subject to the following two conditions: (1) this device may not cause harmful interference, and (2) this device must accept any interference received, that may cause undesired operation.

Le présent appareil est conforme aux CNR d'Industrie Canada applicables aux appareils radio exempts de licence. L'exploitation est autorisée aux deux conditions suivantes: (1) l'appareil ne doit pas produire de brouillage, et (2) l'utilisateur de l'appareil doit accepter tout brouillage radioélectrique subi, même si le brouillage est susceptible d'en compromettre le fonctionnement.

**Warning:** Changes or modifications to the equipment not approved by Peavey Electronics Corp. can void the user's authority to use the equipment.

**Note** – This equipment has been tested and found to comply with the limits for a Class B digital device, pursuant to Part 15 of the FCC Rules. These limits are designed to provide reasonable protection against harmful interference in a residential installation. This equipment generates, uses, and can radiate radio frequency energy and, if not installed and used in accordance with the instructions, may cause harmful interference to radio communications. However, there is no guarantee that interference will not occur in a particular installation. If this equipment does cause harmful interference to radio or television reception, which can be determined by turning the equipment off and on, the user is encouraged to try and correct the interference by one or more of the following measures.

- Reorient or relocate the receiving antenna.
- Increase the separation between the equipment and receiver.
- Connect the equipment into an outlet on a circuit different from that to which the receiver is connected.
- Consult the dealer or an experienced radio/TV technician for help.

## Caution

The equipment complies with FCC radiation exposure limits set forth for an uncontrolled environment.



# Peavey® Invective® MH

Congratulations on the purchase of your new Invective MH tube guitar amplifier from Peavey! Although small, this amp has an all-tube preamp and power amp to authentically produce the much loved tones of the Invective 120-- albeit at lower power levels. The major advantage is the sheer size and weight (or lack thereof).

Before you begin playing through your amplifier, it is very important to ensure that the product has the proper AC line voltage supplied. This is shown on the voltage selector switch near the IEC inlet on the rear panel of the unit. Refer to the rear panel diagram in this manual to locate the particular feature next to its number.

Please read this guide carefully to ensure your personal safety as well as the safety of your amplifier. A careful reading of this manual will also ensure you get the best out of your amplifier, by fully understanding its many features.

## FEATURES:

- 2x EL84 power tubes and 3x 12AX7/ECC83 preamp tubes
- Clean Channel with Low and High EQ.
- Lead Channel with 3 band EQ.
- Footswitchable Tight on Lead channel.
- Footswitchable Gate and Boost on Lead Channel.
- Footswitchable buffered effects Loop
- Tube Status Indication (T.S.I.) circuit
- Impedance switch for 16 or 8 ohm cabinets
- MSDI™ Output with XLR and ground lift switch
- USB Output
- Speaker defeat switch
- Headphone output
- Attenuator switch for 20 watts, 5 watts or 1 watt output power
- Master Resonance and Presence.



**VENTILATION:** For proper ventilation, allow 24" clearance from the nearest combustibile surface.

All vents should have a minimum of 2" of free air space so air can flow thru the unit freely for proper cooling.

# Invective MH® Front Panel

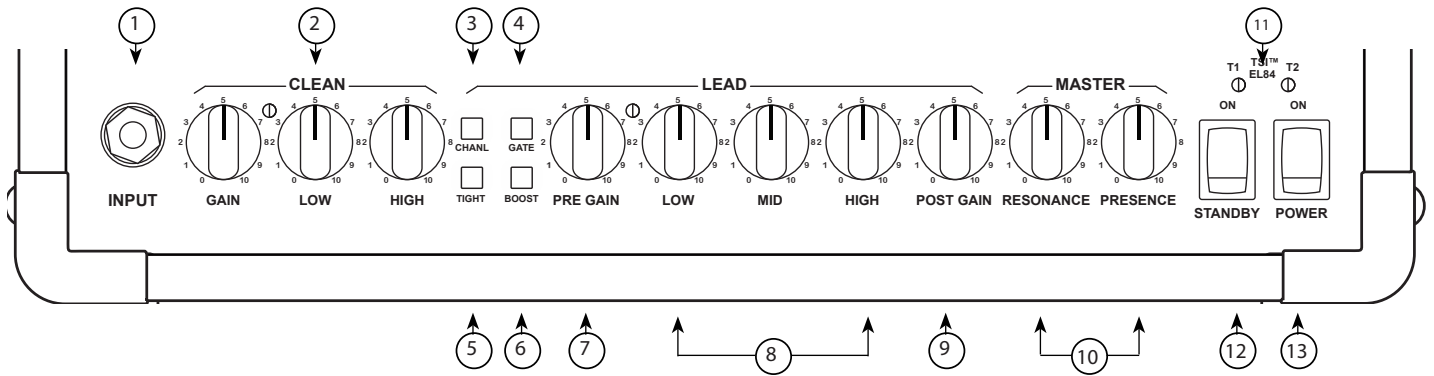

- 1 INPUT  
Standard 1/4" jack for connection to the output of your guitar or last pedal if using effects before the amp.
- 2 Clean Channel Gain and EQ controls  
Volume control for Clean channel and passive tone controls that regulate the low (bass) and high (treble) frequencies of the clean channel's tone.
- 3 CHANNEL SWITCH  
Allows selection of the two different channels. The "IN" position of the switch selects the 'LEAD' channel and the "OUT" position selects the 'Clean' channel.  
NOTE: Channel selection may also be achieved by using the included footswitch.  
If remote selection is desired, the CHANNEL switch (#2) must be set to the "IN" position.
- 4 GATE SWITCH  
This activates the footswitchable preset input gate function when engaged. Rather than being a simple noise gate, the intention is that this be used in conjunction with the Lead BOOST (6) to achieve a more "precise" muting characteristic in the highest gain modes while controlling all of that insane tube gain. The combination of this switch setting and the BOOST (6) switch setting will determine what the BST+GATE (26) footswitch jack will toggle on/off when the footswitch is connected. Whichever switches are pushed "in" will also be controllable via the footswitch with a single push of the button.
- 5 TIGHT Switch  
This activates the footswitchable TIGHT function when engaged. The TIGHT function reduces the gain and alters the EQ of the Lead channel to provide a quasi-third channel that mimics the CRUNCH channel on the original Invective 120 head for a more articulate and full sounding high gain option than that of the full blown onslaught of the Lead channel. This switch setting must be engaged for footswitch operation when connected to the TIGHT footswitch jack (26).
- 6 BOOST Switch  
This activates the footswitchable preset input boost function when engaged. Like the Invective 120 head, this Lead Boost is similar to Misha's favorite TS style boost but at a given setting to save front panel space. The combination of this switch setting and the GATE (4) switch setting will determine what the BST+GATE (26) footswitch jack will toggle on or off when the footswitch is connected as described earlier.
- 7 LEAD PRE-GAIN  
This controls the input volume level of the LEAD CHANNEL and, therefore, the amount of gain and overdrive.
- 8 LOW, MID & HIGH EQ controls  
These are passive tone controls that regulate the low (bass), mid and high (treble) frequencies of the tone of the Lead channel.

### 9 POST-GAIN controls

This controls the output level of the LEAD channel. Used to set the volume as well as to balance the sound between the two channels.

### 10 RESONANCE and PRESENCE

Allows for adjustment of the damping factor of the power amplifier. Damping is the ability of an amplifier to control speaker cone motion after the signal disappears. A higher damping factor reduces cone vibration more quickly than a lower damping factor in the affected frequency range. The actual damping factor of the amplifier decreases as the knobs are turned up. Resonance works on the low end and Presence exclusively affects the high end response of the power amp.

### 11 OUTPUT TUBE STATUS INDICATION (T.S.I.™) LEDS

These are LEDs that light green or red depending on the status of the output tube they are monitoring. These are merely the visual part of the wider status indication, fault detection and tube protection circuits. The LEDs T1 and T2 relate to the EL84 power tubes from left to right (when viewed from the front).

The simple explanation of this circuit is that the LED will be green in normal working mode and red in any other mode, including: Standby, low bias, low current (tube wearing out) or high current fault condition that has activated in the tube protection circuit.

The more complete explanation is as follows:-

On Standby, the LEDs should be red. This is due to the tubes not yet being fully on.

When switching from STANDBY to ON, these should then turn from red to green.

The LEDs will remain green, under normal operating conditions.

If an LED goes red then it means that the output tube is not working properly for one of the following reasons:

- Tube is 'under current': This could be due to incorrect bias, low current due to aging, open circuit due to structural/physical fault or missing filament heater supply.
- Tube has gone 'over current': In this case the resettable protection circuit will be switched in to protect against further damage and to allow the amplifier to carry on working with the remaining tube. This could be due to bias failure, over-heating of the tube or other fault condition resulting in excessive current draw.

Reset: Under certain conditions (e. g. during an adequate pause in playing), the protection circuit will auto-reset and allow the tube to be turned back on. If the fault remains then the LED will stay red. In these situations, at a convenient point, the amp should be turned off for a few minutes then back on again. If the fault is still there, then the amp should be checked by a qualified and competent technician for correct output tube bias or faulty tube(s).

### 12 STANDBY switch

Placing this switch in the "STANDBY" position will effectively shut the amp off while leaving the tube filaments on. Leave this switch in the "STANDBY" position for a minimum of one (1) minute after engaging the POWER switch (13). This is also a useful feature, since much tube wear comes from the heating and cooling of the tube itself. Leaving the unit in "STANDBY" when you take a break allows the tubes to stay warm while you are not playing. To immediately resume normal amp operation with no warm-up delay, place the switch in the "ON" position. NOTE: This switch does not replace the POWER switch. When you are ready to stop playing for an extended period of time\*, it is better to turn the amp off via the POWER switch. To prevent any undesirable noise, it is recommended to switch the amp to "STANDBY" for at least a few seconds before switching fully off.

\* Excessive time off (more than one hour) in "STANDBY MODE" can damage OUTPUT TUBE by "poisoning the cathodes".



### 13 POWER switch



To apply power to the unit, connect the line cord and flip the switch to the ON position. Three of the four front panel LED's should illuminate, indicating power is being supplied. It's best that the STANDBY switch (12) is set to STANDBY when amp is first switched on.

The correct start up sequence is:-

- \*Before use, both switches should be in the 'down' position.
- \*Switch POWER to ON. Now wait at least 1 minute for the amplifier to warm up.
- \*Then switch the STANDBY to ON. Use amp as normal.
- \*Switch to STANDBY for short breaks. (Between sets, not between songs!)
- \*When through playing, switch to STANDBY, wait at least a few seconds, then switch POWER to OFF.

## Invective MH<sup>®</sup> Rear Panel

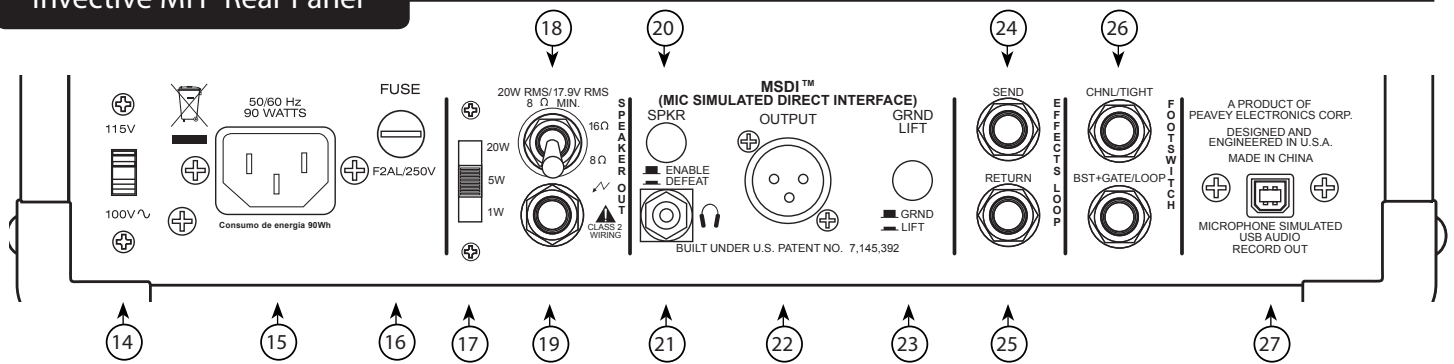

### 14 VOLTAGE SELECTOR SWITCH



This selects between two different AC line/mains voltages. This should not normally be adjusted by the user, hence the clear plastic shield. This should already be set to the correct line/mains voltage in your country/territory.

### 15 AC POWER INLET:



This is the receptacle for an IEC line cord, which provides AC power to the unit. Connect the line cord to this connector to provide power to the unit. Damage to the equipment may result if improper line voltage is used. (See VOLTAGE SELECTOR SWITCH #14).



Never break off the ground pin on any equipment. It is provided for your safety. If the outlet used does not have a ground pin, a suitable grounding adapter should be used and the third wire should be grounded properly. To prevent the risk of shock or fire hazard, always make sure that the amplifier and all associated equipment is properly grounded.

#### Note for UK ONLY

As the colors of the wires in the mains lead of this apparatus may not correspond with the colored markings identifying the terminals in your plug, proceed as follows: (1) The wire that is colored green and yellow must be connected to the terminal that is marked by the letter E, or by the Earth symbol, or colored green or green and yellow. (2) The wire that is colored blue must be connected to the terminal that is marked with the letter N, or the color black. (3) The wire that is colored brown must be connected to the terminal that is marked with the letter L, or the color red.

To avoid the risk of electrical shock, do not place fingers or any other objects into empty tube sockets while power is being supplied to unit.

### 16 FUSE



The fuse is located within the cap of the fuseholder. If the fuse should fail, IT MUST BE REPLACED WITH THE SAME TYPE AND VALUE IN ORDER TO AVOID DAMAGE TO THE EQUIPMENT AND TO PREVENT VOIDING THE WARRANTY. If the amp repeatedly blows fuses, it should be taken to a qualified service center for repair.

WARNING: THE FUSE SHOULD ONLY BE REPLACED WHEN THE POWER CORD HAS BEEN DISCONNECTED FROM ITS POWER SOURCE.

### 17 POWER OUTPUT SWITCH

This three position switch controls an attenuator which allows the maximum output of the amplifier to be switched between 100%, 25% and 5% of rated power. Therefore, between 20 watts, 5 watts and 1 watt. This enables the user to drive the power stage hard, therefore producing the characteristic power amp overdrive, but without such loud volumes being produced by the speaker.

On the lower settings it may be necessary to slightly increase the Resonance and Presence controls for the desired tone. This is due to the change in damping factor when the speaker is driven less.

### 18 IMPEDANCE SELECTOR

This switch allows the appropriate selection of speaker/cabinet impedance between either 16Ω or 8Ω.

If two enclosures of equal impedance are used, and connected in parallel by linking the two, the switch should be set to half the individual value. For example, two 16Ω enclosures necessitate an 8Ω setting. Minimum speaker load impedance is 8Ω.

### 19 SPEAKER OUTPUT

The speaker output is provided for connection to an external speaker cabinet. Please ensure a proper speaker cable is used and not a shielded type instrument cable. The load impedance is selectable via the IMPEDANCE SELECTOR (18).



The Invective MH sounds great into a 1x12, but try this into a 4x12 and see the reaction you get! **DO NOT connect a speaker while the power is turned on!**

### 20 SPEAKER ENABLE/DEFEAT SWITCH

This feature effectively disconnects any speaker/cabinet connected to the SPEAKER OUTPUT (19) and redirects the output to an internal dummy load. This enables the user to monitor their playing using the signal from either the MSDI™ output, USB output or headphone output, without producing any real volume. Therefore, they can play or record at much lower volume levels.



**Always use this feature whenever the amp is used without a cabinet connected to the SPEAKER OUTPUT (19).**

### 21 HEADPHONE OUTPUT

This is for connection to normal headphones/earphones via a stereo mini-jack.

The user can set the amp to the SPEAKER DEFEAT setting and practice silently with headphones. The signal is derived from the MSDI™ circuit (see below), therefore is filtered for a 12” guitar speaker-like tone.

### 22 MIC SIMULATED DIRECT INTERFACE - MSDI™

Peavey's exclusive MSDI™ simulates the sound of a microphone placed approximately 3” from a loudspeaker cone, allowing the user to send an accurate good quality signal to the mixing console, without any acoustic spill from other instruments on stage. This is a non-powered output and safe for use with any mixing console. It is also particularly useful for home recording.

### 23 GROUND LIFT

Engage this switch if the mix engineer is hearing a hum in the MSDI™ output. This should eliminate the hum by removing the ground loop. Otherwise, leave in the 'out' setting, 'GRND'.

### 24 EFFECTS LOOP SEND

This 1/4” output jack supplies signal to external low-level effects or signal processing equipment. Although the actual effects loop is footswitchable, the SEND output is always active which can make it useful for sending the preamp signal to another amplifier.



25 EFFECTS LOOP RETURN

1/4" input jack for returning signals from external low-level effects or signal processing equipment. This is a switching jack: Inserting a plug into this jack will break the signal path from the EFFECTS SEND (24) jack. If the effects loop is used, then it will automatically be on. However, a footswitch can also be used to bypass the effects loop-- see below.

26 FOOTSWITCH JACKS

Provides for connection of one or two Peavey Multi-purpose 2-button Footswitch w/LEDs (#03022910). One such footswitch is included with the amplifier.

Top Jack (CHNL/TIGHT):

"1" (ring): Selects between Clean and Lead channels (3) when engaged on the front panel.

"2" (tip): Selects TIGHT (5) function when engaged on the front panel.

Bottom Jack (BST+GATE/LOOP):

"1" (ring): Activates the EFFECTS LOOP (24/25) when the LED is on. Effects loop is active by default when the footswitch is not connected.

"2" (tip): Selects BOOST (6) and/or GATE (4) functions in conjunction with whichever is engaged on the front panel (i.e.: If both switches are engaged, then both functions will activate when the footswitch is depressed; if only one of them is engaged, then only the one that is depressed will activate when the footswitch is depressed; and if neither switch is engaged, then the footswitch will have no effect).

When using a footswitch, always insert the plug fully (second click) into the FOOTSWITCH jacks to ensure proper operation.

27 MICROPHONE SIMULATED USB AUDIO RECORD OUTPUT

The USB Record Output requires no additional drivers – just plug a standard USB 2.0 cable into your computer and it will detect it as an audio device. Open your favorite recording program and start recording. The output is derived from the MSDI™ so will sound great right into your computer.

This can be used in any setting of the POWER OUTPUT (17) or SPEAKER DEFEAT (20) switches and there should be little comparative differences in USB audio level. Therefore a good strong signal can still be recorded while the amp is set to 5% power or even silent.

The actual level of the signal from the USB out will be dependent on the settings of the controls. However each unit has been calibrated so that a very wide range of sounds and levels will all fit within the USB headroom. Like with any recording, especially digital, the actual recording levels should be set so as to prevent any unwanted distortion.

\* Power tubes

Warning!!! If the power tubes (EL84) are changed, then the amplifier should be re-biased. We have designed them so this is a fairly quick and easy procedure, but this should be carried out by a qualified and competent technician/engineer. This is not only due to safety, but also to ensure the user gets the best sound and longevity from their new tubes. Incorrectly biased power tubes can either sound dirty and lifeless or burn out unnecessarily quickly.

Matched power tubes are recommended.



# Invective MH<sup>®</sup>

## All-Tube Guitar Amplifier SPECIFICATIONS

**Rated Power:** 20 W(rms) into 8 or 16 $\Omega$

A second footswitch can be used for turning Boost + Gate and/or effects loop on and off.

**Power Consumption:** (Domestic) 90 W, 50/60 Hz, 120 VAC

### Other Misc Specifications

**Tube Complement:** 2 x EL84, 3 x 12AX7/ECC83

### Signal to Noise Ratio:

Better than 74dB on all models (compared to full power and dependent on preamp settings)

**Dimensions (H x W x D):** 7.25" x 14.00" x 7.75" / 185mm x 356mm x 197mm (height includes feet and handle)

### MSDI Output:

**Low Impedance:** 600 $\Omega$  - Quasi-Balanced

**Weight:** 17 lbs / 8kg

**Output Level:** Dependent on controls but -12dBu (+/-3dBu) at full power on all models

### Preamp Specifications

#### Preamp Input:

**Impedance:** Very High-Z, 1M $\Omega$

#### USB Output:

**Output Level:** Dependent on controls but -6dB (+/-3dB) at full power on all models

#### Effects Send:

**Low Impedance:** To High-Z, 22k $\Omega$  or greater

**Nominal Output Level:** 0 dBV, 1.0 V(rms)

#### Power attenuator:

Three setting switch for 100%, 25% and 5% of rated power. (20W, 5W and 1W respectively.)

#### Effects Return:

**Impedance:** High-Z, 100k $\Omega$

**Designed Input Level:** 0 dBV, 1.0 V(rms)

#### Headphone Output:

Stereo mini-jack with filtered output for driving stereo headphones, 16 $\Omega$  - 50 $\Omega$  impedance per side.

#### Remote Footswitch(s): (included)

Special 2-button unit with LED indicators (#00579720)

One footswitch for channel selection and tight functions.

**\*Features and specifications subject to change without notice.**





[www.peavey.com](http://www.peavey.com)

Warranty registration and information for U.S. customers available online at  
[www.peavey.com/warranty](http://www.peavey.com/warranty)  
or use the QR tag below



Features and specifications subject to change without notice.

Peavey Electronics Corporation 5022 Hartley Peavey Drive Meridian, MS 39305 (601) 483-5365 FAX (601) 486-1278



Logo referenced in Directive 2002/96/EC Annex IV  
(OJ(L)37/38,13.02.03 and defined in EN 50419: 2005  
The bar is the symbol for marking of new waste and  
is applied only to equipment manufactured after  
13 August 2005