

OPERATING INSTRUCTIONS

IPS™ 400

DUAL CHANNEL

INDUSTRIAL POWER

AMPLIFIER



Front Panel

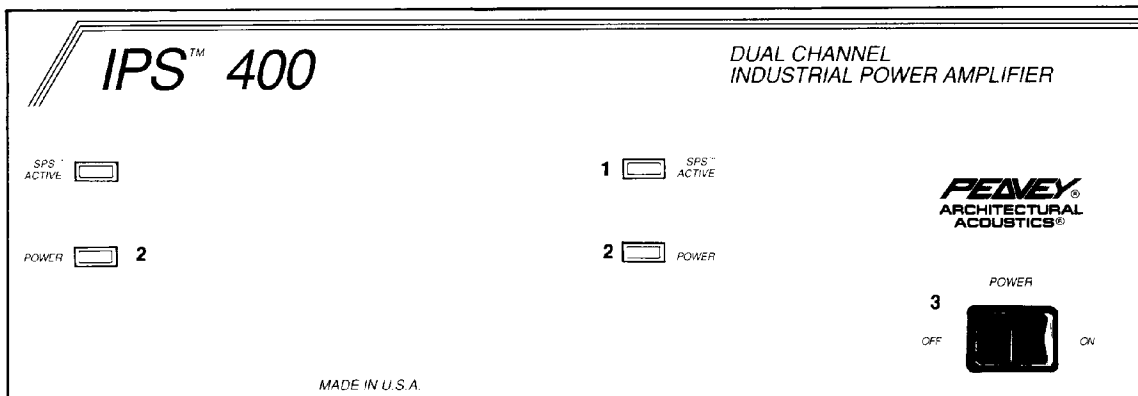

SPS ACTIVE LED (1)

Illuminates when SPS Compression is taking place. With the ENABLE/DEFEAT switch in the DEFEAT position, the LED indicates when clipping distortion is occurring.

SPS COMPRESSION

The compression system is activated by our exclusive SPS compression circuitry that senses conditions that might overload the amplifier and activates compression when clipping is imminent. In other words, compression takes place whenever signal conditions exist which prevent the amplifiers from faithfully reproducing the input signal. Threshold then is clipping itself and no specific threshold control is provided. This technique effectively utilizes every precious watt available from the power amplifier, and at the same time prevents damage to the speakers due to the absence of power amp clipping. The SPS System is an automatic hands-off approach to the problem of power amp clipping. SPS is designed to maximize the dynamics

available from the amplifier within its power output capabilities regardless of power supply/AC line voltage variations and load impedance selection.

POWER LED (2)

Illuminates when AC power is being supplied to the amp and the associated channel is operational. Illumination is delayed slightly during the power-up cycle due to the transient suppression/thermal/fault circuitry. If either channel were to experience fault conditions or to exceed the safe operating temperature limits, then that channel will shut down, and the associated power LED will go out, indicating such conditions exist. Also, whenever the BRIDGE mode is selected, the power LED on channel B is defeated (OFF), just as if there were a fault condition on channel B. This provides a positive indication that the IPS™-400 is in bridge mode.

POWER SWITCH (3)

Depress to "On" position to turn on.

Rear Panel

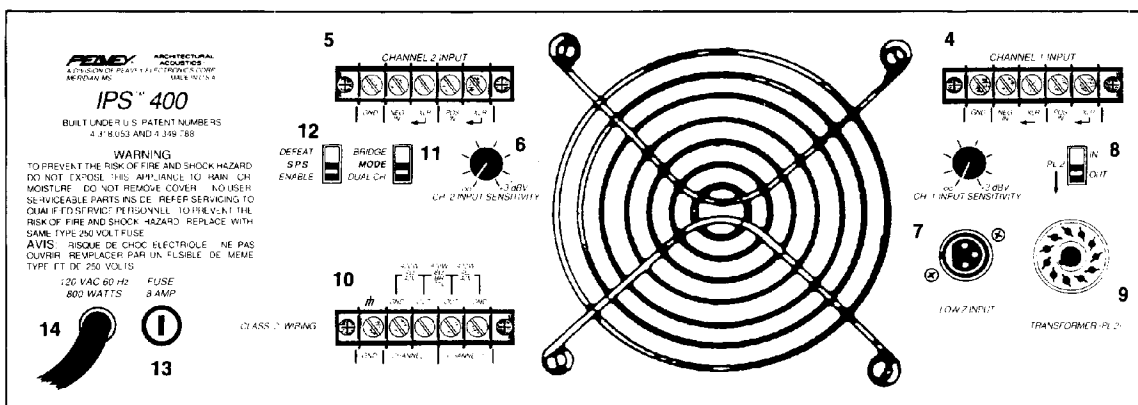

CHANNEL 1 INPUT TERMINAL STRIP (4)

First this strip contains the input connections for channel 1. These are labeled POS IN, NEG IN, and GND, and they can be treated like any other conventional differential input with one important exception. The NEG IN terminal has a relatively low impedance to ground (about 47 ohms), and should only be used for the "shield" connection in a

single conductor, shielded cable application, or as the extra ground run in a two conductor, shielded cable application. Under no circumstance should it be used as an input per se. The POS IN terminal must always be used as the channel input and as such it presents a relatively high impedance of 20K ohms. This unique differential circuitry is called QUASI-BALANCED and when used

properly, is a very effective means to eliminate "ground loops." Such loops often occur when unbalanced cable patches are made between various pieces of equipment that share the same rack. A QUASI-BALANCED input will allow "hum free" operation in typical rack configurations and even when relatively short cable patches are made from the various outputs of other equipment that share the same main power receptacle. This feature becomes ineffective with longer cable runs due to the increased cable resistance. The QUASI-BALANCED feature is defeated when the NEG IN is connected to GND. Several neat patching arrangements will be presented later in this manual. The remaining two terminals on this strip are labeled XLR and are used with jumpers to patch the signal from the XLR (LOW Z INPUT) circuitry to this channel. This feature will be discussed shortly.

CHANNEL 2 INPUT TERMINAL STRIP (5)

Obviously, this strip contains the input connections for channel 2, which are labeled POS IN, NEG IN, and GND. These terminals are to be treated in the same manner as discussed in the channel 1 input, having the QUASI-BALANCED feature. These input connections are not used and rendered useless whenever the bridge mode is selected. The bridge mode will be discussed later. Again, the two terminals labeled XLR can be used with jumpers to patch the signal from the XLR (LOW Z INPUT) circuitry to this channel, thereby creating a common low Z balanced input for both channels.

CHANNEL 1 & 2 INPUT SENSITIVITY CONTROLS (6)

We have provided an input sensitivity control for each channel to allow the flexibility of setting different signal levels in each channel which might be required in a typical two zone distribution system. These controls are screw-driver type, allowing precise level setting; but as such should help to eliminate any inadvertent or accidental changes in level. Maximum input gain (minimum sensitivity rating) is achieved at the full clockwise setting. A setting of less than full clockwise will yield lower system noise at the expense of system headroom. Full clockwise calibration is 0 dBV (1 V RMS), which is the input signal level necessary to achieve rated output power. Although not very accurate, and therefore not labeled accordingly, each line marking below full clockwise setting is approximately -3 dB less gain.

LOW Z INPUT (7)

A conventional three-pin, female XLR input jack is provided and may be used as the input for either or both channels. When the (PL-2) line-balancing transformer is not used, and the PL-2 switch is set to "OUT," this XLR input becomes QUASI-BALANCED with pin #3 as the positive input (connecting to POS IN on the channel input strips above), pin #2 as the negative input (connecting to NEG IN on the channel 1 input strip above), and pin #1 going to chassis ground. When the (PL-2) line balancing transformer is used, and the PL-2 switch is set to "IN," this XLR input becomes fully TRANSFORMER-BALANCED (Pin #3 positive, pin #2 negative, pin #1 ground; USA standard).

PL-2 SELECTOR SWITCH (8)

This switch is to be used in conjunction with the PL-2 transformer to allow the LOW Z INPUT to function with or without a PL-2 module being inserted in the receptacle. The "OUT" position selects the "QUASI-BALANCED" mode of operation for the LOW Z INPUT (XLR jack), and routes the input signal directly to the channel 1 input strip. In this position, the input strip may be used as an output after the LOW Z INPUT to allow patching this signal to other amplifiers. Normally, in this switch position, a PL-2 transformer is not present (OUT) in the transformer receptacle. However, if one were IN the receptacle, the LOW Z INPUT would still be QUASI-BALANCED, and it

becomes TRANSFORMER-BALANCED only when the IN switch position is selected. Notice then, this is a very effective means to "test" for the necessity of a line-balancing transformer. The "IN" position of the switch routes the input signals from the XLR jack through the PL-2 transformer, thus selecting the TRANSFORMER-BALANCED mode of operation for the LOW Z INPUT. In this position the input terminal strip may be used as outputs after the line-balancing transformer to patch this signal to other amps. If the "IN" position is selected without a PL-2 line-balancing transformer "IN" the receptacle, the LOW Z INPUT will be rendered inoperable.

TRANSFORMER RECEPTACLE (9)

This receptacle only receives the optional (PL-2) line-balancing transformer. When conditions exist that demand the usage of a TRANSFORMER-BALANCED XLR INPUT at the input of channel "A," the (PL-2) transformer must be put here, and the selector switch must be in the "IN" position.

CHANNEL OUTPUTS TERMINAL STRIP (10)

This strip contains the outputs of both channels. These terminals are arranged so as to provide separate feeds from each channel or to provide bridge mode operation from two adjacent terminals. There are terminals for each channel output and ground, and an extra ground terminal to permit the grounding of external equipment to this amplifier. All three ground terminals can be used interchangeably since they all are chassis ground.

DUAL CHANNEL OPERATION:

Each channel of the IPS 400 is rated at 200 W RMS into 4 ohms. The terminals labeled CHANNEL 1 & CHANNEL 2 below the strip, represent the output pair for each channel. Labeling above each indicates 200 W, 4 ohms, and 25 volts. 200 W RMS into 4 ohms is 28 V RMS; thus, these terminal pairs can each be used as dual 25 VOLT LINES. These output pairs can also be used to drive two separate loudspeaker loads. The minimum parallel speaker load should be no less than 4 ohms. Operation at loads above 4 ohms and even open circuit conditions can always be considered safe. However, sustained operation at loads below 4 ohms could result in temporary channel shutdown due to the thermal limits and/or the amplifier's internal fault circuitry. These output pairs can also be connected to separate distribution output transformers (like the Peavey AUTOMATCH) to create a higher distributed voltage level system (typically 70 or 100 V RMS). **WARNING:** The output transformers must be able to handle 200 W RMS continuous (the AUTOMATCH transformer is rated a 400 W RMS continuous). Also, be sure to wire them correctly (the ground terminals are on each end of the strip).

BRIDGE CHANNEL OPERATION:

When a two-channel amplifier is operated in BRIDGE MODE, it is converted to a single channel amp, with a power rating and a load rating of TWICE that of the single channel ratings. For the IPS-400, this rating is 400 W RMS into 8 ohms (the single channel rating is 200 W RMS into 4 ohms). The bridge mode operation is accomplished by placing the mode switch in the bridge position, connecting the "load" between the output terminals of the individual channels, and using channel 1 as the input channel (the input of channel 2 functions as an input being defeated). As mentioned, these output terminals are both located next to each other for convenience.

A TECHNICAL DESCRIPTION:

Labeling above these terminals is 400 W, 8 ohms, and (BR). This deserves a brief technical description. In "bridge" mode, Channel 2 is supplied internally with an input signal which is equal in level, but is 180 degrees out-of-phase from that of the channel 1 input signal. This

input signal trick then causes the individual channel outputs to also be out-of-phase, so that, for example, when one channel signal swing is positive, the other channel signal swing is negative. Thus the load, which is now connected "between" the individual channel outputs, actually "sees" the sum of output voltages of both channels ($28 + 28 = 56$ V RMS), this load must be twice the value of the single channel load value ($4 + 4 = 8$ ohms), and the power that is delivered to this load will be twice the single channel rating ($200 + 200 = 400$ W RMS). In essence, we now have a 56 VOLT LINE. Hence, this "bridged" amplifier can now be used to drive any 8 ohm load that is capable of handling 400 W RMS. This load can be loudspeakers, a distribution transformer (like the Peavey AUTOMATCH), or even a 70 volt distribution system directly, the latter being accomplished without using a large and expensive output transformer, resulting in a very simple and cost effective approach. The labeling then above the output terminals on this unit, (BR), is the choice of many contemporary sound engineers for applications that are cost sensitive. There are, however, a few considerations and limits that must be discussed.

EXCEPTIONS AND LIMITATIONS OF BRIDGE MODE OPERATION:

First, most bridged amps have an 8 ohm minimum load rating, thus the 70 volt system impedance must be limited to 8 ohms. To comply with this, then, right up front, one could design the size of the 70 volt system to 600 W (an ideal 600 watt, 70 volt system has an impedance value of 8 ohms). Now, continuing, most experienced installers use a simple two-thirds rule where they limit the system size to two-thirds of the power amplifier rating because they know that the typical distribution transformer ain't what it's cracked up to be. In this case, this rule would apply to the actual load presented to the amplifier, and it should still be imposed. Thus, two-thirds of 600 is 400. That's right, a smart technical type will install a maximum 400 watt system on this 400 W RMS "bridged" amp. Unfortunately, there is a limit to this approach...

Secondly, because we have a 56 VOLT LINE rather than a 70 VOLT LINE, all the 70 volt "parts" (transformers, speakers) will be "underpowered" to 67% of the expected value (i.e., 267 W RMS on our 400 watt system), so we will get slightly lower performance levels than normal (approximately 1.5 dB lower). Notice that all of these "crazy" things occurred because a bridged IPS-400 was a 56 volt line and not a 70 volt line. If all this bothers you, we suggest you go the "clean" way and use the 70 volt distribution transformers like the AUTOMATCH unit.

For bridge mode operation, then, one must set the MODE switch to BRIDGE, use channel 1 as the system input, use the channel 1 sensitivity control as the system level control (channel 2 input and sensitivity control not being operational), and connect the load across the indicated BRIDGE terminals. The low Z XLR input can be used if desired by strapping both the terminals labeled XLR to the POS and NEG inputs on the channel 1 input strip only. Do not use the XLR straps on channel 2 whenever the bridge mode is used. **NOTE:** Whenever the BRIDGE mode is selected, the power LED on channel 2 is defeated (OFF). This indicates that the amp no longer has "two channels." You should also set the channel 2 input sensitivity full CCW in this mode. **WARNING:** Never connect separate loads to each channel output when you have selected the BRIDGE mode, because the channel 2 input is not operational in this mode, and the output signal on channel 2 will be identical to that of channel 1, but 180 degrees out-of-phase. If identical signals are desired on both channels, select the DUAL CHANNEL mode and connect the same signal source to both channel inputs. It should be noted that the channel inputs are connected

together (parallel) whenever the dual XLR "straps" are used on both channel input strips, even if the LOW Z INPUT circuitry is not used. Since they are sourced from the same point, this is a neat parallel means.

MODE SWITCH (11)

This switch is used to select either STEREO or BRIDGE mode of operation.

SPS SWITCH (12)

This switch is used to either ENABLE or DEFEAT the SPS compressor.

FUSE (13)

The fuse is located within the cap of the fuseholder. If the fuse should fail, IT MUST BE REPLACED WITH THE SAME TYPE AND VALUE IN ORDER TO AVOID DAMAGE TO THE EQUIPMENT AND TO PREVENT VOIDING THE WARRANTY. If the amp repeatedly blows fuses, it should be taken to a qualified service center for repair.

WARNING: THE FUSE SHOULD ONLY BE REPLACED WHEN THE POWER CORD HAS BEEN DISCONNECTED FROM ITS POWER SOURCE.

MAINS POWER SOURCE (120 V PRODUCTS ONLY) (14)

The IPS-400 is fitted with a single heavy duty #14AWG, 3 conductor line cord and a conventional AC plug with a ground pin. It should be connected to an independent circuit capable of supporting at least 10 AMPS continuously or greater. This is particularly critical for sustains high power applications. If the socket used does not have a ground pin, a suitable ground lift adaptor should be used and the third wire grounded properly. Never break off the ground pin on the IPS-400. The use of extension cords should be avoided, but if necessary, always use a three-wire type with at least a #14AWG wire size. The use of lighter wire will severely limit the power capability of this amplifier. Always use a qualified electrician to install any necessary electrical equipment. To prevent the risk of shock or fire hazard, always be sure that the amplifier is properly grounded.

INSTALLATION AND CONNECTION:

The Peavey Architectural Acoustics IPS-400 commercial series power amplifier is designed for durability in commercial installations and the quality of performance required in studio and home applications. The unit is a standard rack-mount configuration, 5¼" high, and is cooled by an automatic two-speed internal fan. All input and output connections are on the back panel. The front panel contains LED indicators for power and DDT™ activation, and a mains power switch.

INDUSTRIAL AND COMMERCIAL INSTALLATIONS:

For commercial and other installations where sustained high power operation is required, the amplifiers should be mounted in a standard 19" rack. It is not necessary to leave rack space between each amplifier in the stack, since the fan pulls air in from the rear and exhausts the hot air out the front. An adequate "COOL" air supply must be provided for the amplifier when rack-mounted. The internal fan must have a source of air that is not preheated by other equipment. The amplifier will start up in "LOW SPEED" fan operation, and will normally stay at low speed operation unless sustained high power operating levels were to occur. Then, as the amplifier "HEAT SINKS" heat up, the automatic thermal sensing circuitry will cause high speed operation to occur. Depending upon signal conditions and amp loading, high speed fan operation may continue, or it may cycle continuously between high and low. This situation is quite normal. If cooling is inadequate due to preheated air, or a reduction of air flow occurs due to blockage of the amplifier inlet/outlet ports, or if the amplifier is severely overloaded or short circuited, then the amplifier thermal sensing system may cause temporary shutdown of that particular channel. This is indi-

cated by the channel power LED on the front panel ceasing to illuminate. Depending upon available cooling air, operation should be restored in that channel relatively quickly, and the power LED will be illuminated. In any event, corrective action should be taken to determine the cause of the thermal shutdown. If the amplifier is not severely overloaded or shorted, and air flow is normal in and out of the amplifier, then steps should be taken to provide a cooler environment for all the amplifiers. As a general rule, the cooler electronic equipment is operated, the longer its useful service life. You have invested in the finest equipment that money can buy, and a little care will ensure long and reliable operation.

STUDIO AND HOME INSTALLATION:

In most low to medium power applications, the power amplifier can be mounted in any configuration. It is desirable that, if at all possible, the power amplifier be located at the top of an equipment stack. This will prevent possible overheating of sensitive equipment by the hot air rising from the power amplifier. As a general rule, most home and studio requirements will never cause high speed fan operation. If it does, however, this may indicate that you have not taken the necessary steps to provide adequate cooling. Remember... closed up in a cabinet, the IPS-400 will have severe cooling problems, even at low power levels. Again, inadvertent short circuit or sustained overload usage could also cause temporary thermal shutdown.

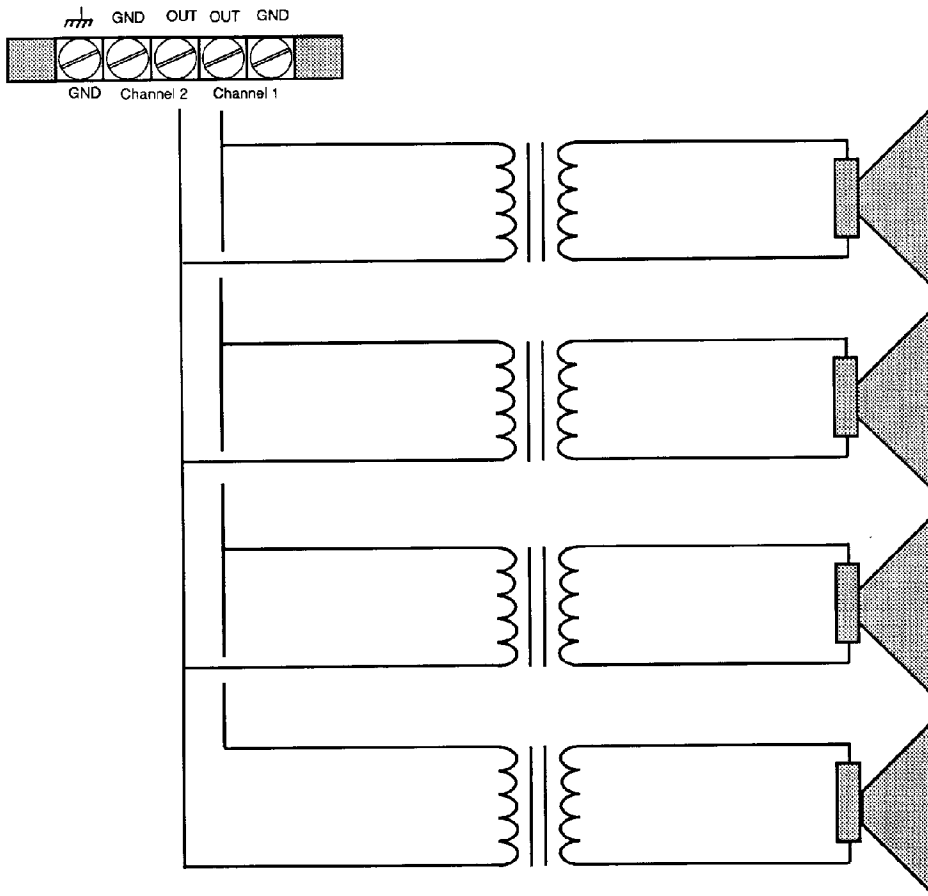

Fig. 1 70V Constant Voltage Distribution System

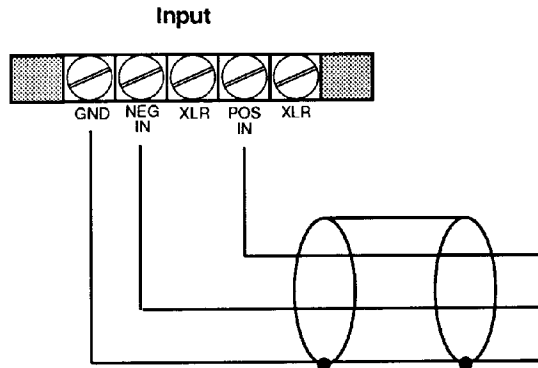

Fig. 2 Balanced Line Level Input Connections

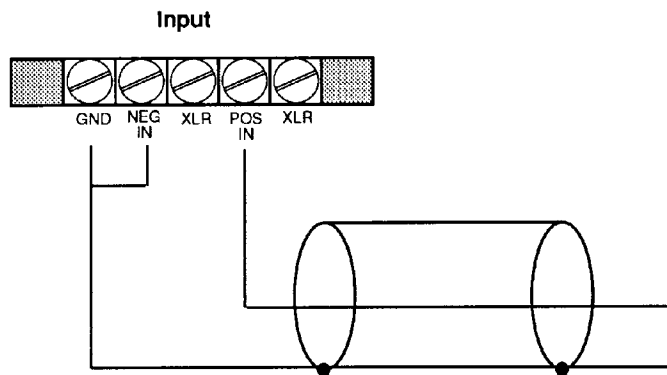

Fig. 3 Unbalanced Line Level Input Connection

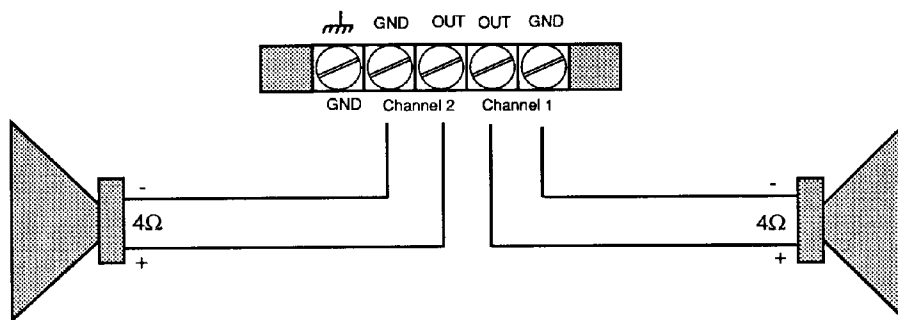

Fig. 4 Direct Output To 4Ω Speakers

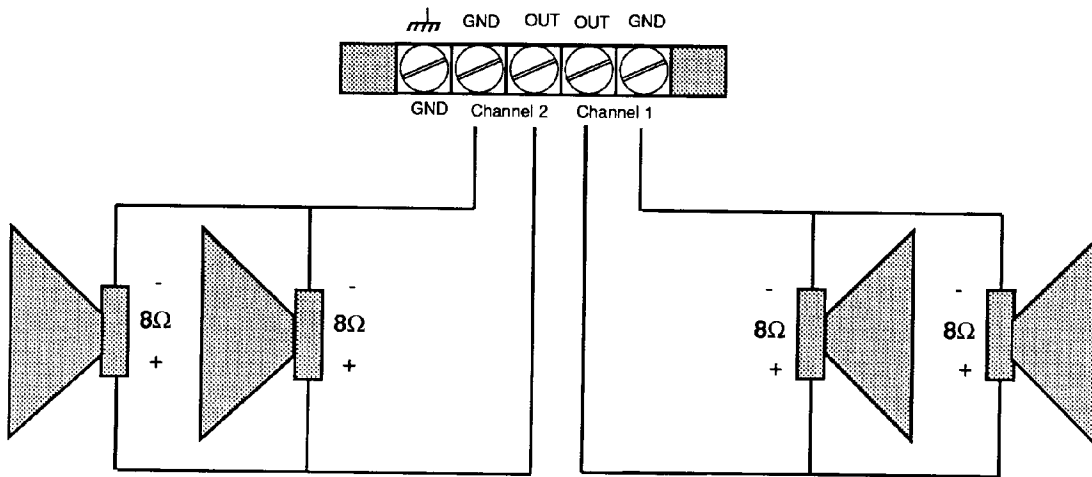

Fig. 5 Direct Output To Multiple Speakers In Parallel Total Impedance = 4Ω Per Channel

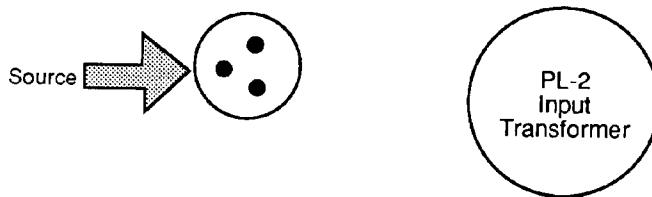
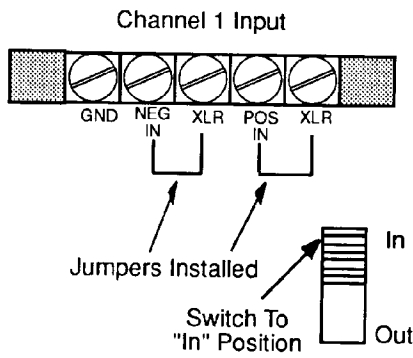
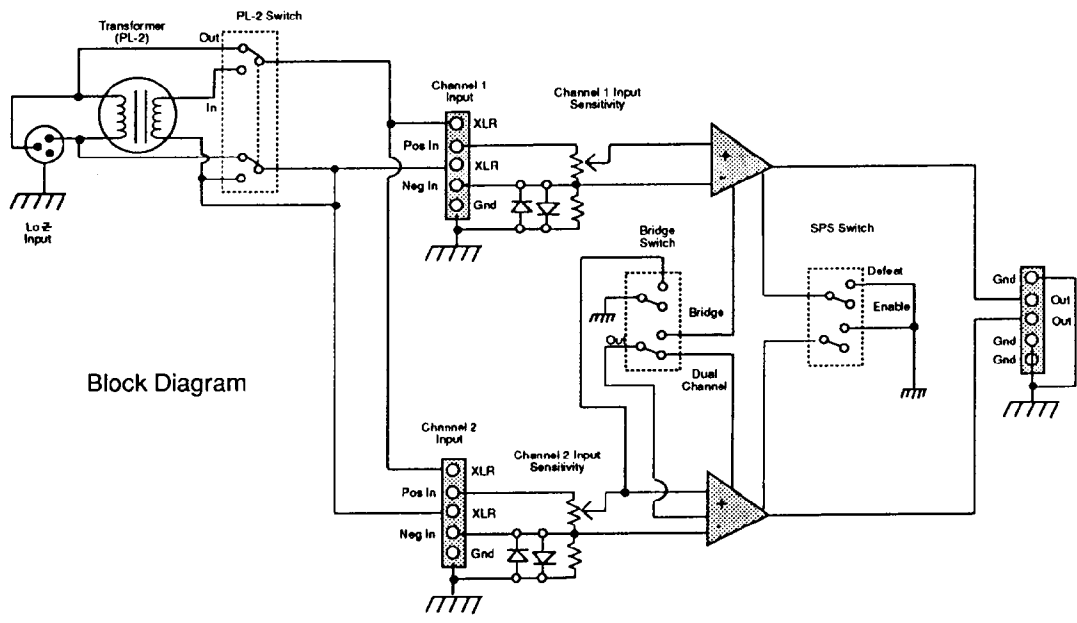

Fig. 6 Transformer Balanced Input Configuration



Block Diagram

IPS™-400 SPECIFICATIONS

RATED POWER

120W RMS per channel into 8 ohms
200 W RMS per channel into 4 ohms
(Both channels driven)
400W RMS into 8 ohms
(Bridge mode)
(Continuous sine wave with less than 0.03% THD, 20 Hz to 20 kHz, 120V AC)
Each channel capable of driving a 25V distribution system to 200W RMS

POWER @ CLIPPING (Typical)

140W RMS per channel into 8 ohms
230W RMS per channel into 4 ohms
150W RMS per channel into 2 ohms
(Both channels driven)
450W RMS Into 8 ohms
(Bridge mode)
(Continuous sine wave with less than 1.0% THD, 20 Hz to 20 kHz, 120V AC)

TOTAL HARMONIC DISTORTION

Less than 0.05% @ 200W RMS per channel into 4 ohms, 10 Hz to 30 kHz
(Typically below 0.03%)

FREQUENCY RESPONSE

+0, -0.2 dB @ 200W RMS per channel into 4 ohms, 20 Hz to 20 kHz
+, -1 dB @ 1W RMS per channel into 4 ohms, 5 Hz to 50 kHz

POWER BANDWIDTH

10 Hz to 50 kHz @ 200W RMS per channel into 4 ohms, less than 0.1% THD

SLEW RATE

40 Volts/microsecond
(Dual channel mode, each channel)
70 Volts/microsecond
(Bridge mode)

DAMPING FACTOR

Greater than 200 @ 4 ohms;
400 @ 8 ohms
(Dual channel mode, each channel, f = 1 kHz)

HUM & NOISE

100 dB below full rated power
(Dual channel mode, each channel or bridge mode, 20 Hz to 20 kHz, unweighted)

INPUT SENSITIVITY & IMPEDANCE

0 dBV (1.0V RMS) into 20K ohms for rated power
(Sensitivity control full clockwise)

DIMENSIONS & WEIGHT

19" W x 5¼" H x 12 ¾" D
40 lbs.

LIMITED WARRANTY

Peavey Electronics Corporation warrants to the original purchaser of this new Architectural Acoustics® product that it is free from defects in material and workmanship. If within one (1) year from date of purchase a properly installed product proves to be defective and Peavey is notified, Peavey will repair or replace it at no charge. (Note: Batteries and patch cords not covered.) "Original purchaser" means the customer for whom the product is originally installed.

Damage resulting from improper installation, interconnection of a unit or system of another manufacturer, accident or unreasonable use, neglect or any other cause not arising from defects in material and workmanship is not covered by this warranty. The warranty is valid only as to products purchased and installed in the United States.

THIS LIMITED WARRANTY IS IN LIEU OF ANY AND ALL WARRANTIES, EXPRESS OR IMPLIED, INCLUDING THE IMPLIED WARRANTIES OF MERCHANTABILITY AND FITNESS FOR A PARTICULAR USE. UNDER NO CIRCUMSTANCES WILL PEAVEY BE LIABLE FOR ANY LOST PROFITS, LOST SAVINGS, INCIDENTAL DAMAGES OR CONSEQUENTIAL DAMAGES ARISING OUT OF THE USE OR INABILITY TO USE THE PRODUCT, EVEN IF PEAVEY HAS BEEN ADVISED OF THE POSSIBILITY OF SUCH DAMAGE. THIS LIMITED WARRANTY IS THE ONLY EXPRESS WARRANTY ON THIS PRODUCT, AND NO OTHER STATEMENT, REPRESENTATION, WARRANTY OR AGREEMENT BY ANY PERSON SHALL BE VALID OR BINDING UPON PEAVEY.

Peavey's liability to the original purchaser for damages for any cause whatsoever and regardless of the form of action, is limited to the actual damages up to the greater of Five Hundred Dollars (\$500) or an amount equal to the purchase price of the product that caused the damage or that is the subject of or is directly related to the cause of action. This limitation of liability will not apply to claims for personal injury or damage to real property or tangible personal property allegedly caused by Peavey's negligence. For information on service under this warranty, call a Peavey customer service representative at (601) 483-5376.

DANGER	
EXPOSURE TO EXTREMELY HIGH NOISE LEVELS MAY CAUSE A PERMANENT HEARING LOSS. INDIVIDUALS VARY CONSIDERABLY IN SUSCEPTIBILITY TO NOISE INDUCED HEARING LOSS, BUT NEARLY EVERYONE WILL LOSE SOME HEARING IF EXPOSED TO SUFFICIENTLY INTENSE NOISE FOR A SUFFICIENT TIME.	
THE U.S. GOVERNMENT'S OCCUPATIONAL SAFETY AND HEALTH ADMINISTRATION (OSHA) HAS SPECIFIED THE FOLLOWING PERMISSIBLE NOISE LEVEL EXPOSURES:	
DURATION PER DAY IN HOURS	SOUND LEVEL (dBA), SLOW RESPONSE
8	90
6	95
4	97
3	100
2	102
1	105
1	110
1	115

ACCORDING TO OSHA, ANY EXPOSURE IN EXCESS OF THE ABOVE PERMISSIBLE LIMITS COULD RESULT IN SOME HEARING LOSS.

EAR PLUGS OR PROTECTORS IN THE EAR CANALS OR OVER THE EARS MUST BE WORN WHEN OPERATING THIS AMPLIFICATION SYSTEM IN ORDER TO PREVENT A PERMANENT HEARING LOSS IF EXPOSURE IS IN EXCESS OF THE LIMITS AS SET FORTH ABOVE. TO INSURE AGAINST POTENTIALLY DANGEROUS EXPOSURE TO HIGH SOUND PRESSURE LEVELS, IT IS RECOMMENDED THAT ALL PERSONS EXPOSED TO EQUIPMENT CAPABLE OF PRODUCING HIGH SOUND PRESSURE LEVELS SUCH AS THIS AMPLIFICATION SYSTEM BE PROTECTED BY HEARING PROTECTORS WHILE THIS UNIT IS IN OPERATION.

CAUTION

THIS MIXING CONSOLE EFFECTS DEVICE/PREAMP HAS BEEN DESIGNED AND CONSTRUCTED TO PROVIDE ADEQUATE SIGNAL VOLTAGE FOR PLAYING MODERN MUSIC. IMPROPER USE OF THE GAIN/EQUALIZER CONTROLS AND/OR IMPROPER USE OF INTERNAL/EXTERNAL BUSES MAY CREATE CLIPPING (SQUARE WAVES) AND POSSIBLY CAUSE SUBSEQUENT DAMAGE TO THE LOUDSPEAKER SYSTEMS. EXTENDED OPERATION OF THE GAIN/EQUALIZATION CONTROLS IN THEIR MAXIMUM POSITION IS THEREFORE NOT RECOMMENDED. PLEASE BE AWARE THAT MAXIMUM POWER CAN BE OBTAINED WITH VERY LOW SETTING OF THE GAIN/EQUALIZATION CONTROLS IF THE INPUT SIGNAL IS VERY STRONG.

IT IS COMMON PRACTICE AMONG USERS OF SOUND REINFORCEMENT EQUIPMENT TO IDENTIFY THE INDIVIDUAL CHANNELS WITH A STRIP OF TAPE PLACED ABOVE OR BELOW THE ROW OF VOLUME FADERS. MANY TYPES OR BRANDS OF TAPE HAVE A VERY STRONG ADHESIVE WHICH CAN INHIBIT THE PAINT ON THE FACEPLATE AND ACTUALLY REMOVE THE PAINT WHEN THE TAPE IS REMOVED. WE STRONGLY RECOMMEND THAT SCOTCH TAPE NOT BE USED ON PAINTED SURFACES NOR ANY OTHER TAPE THAT IS NOT ESPECIALLY DESIGNED FOR SUCH APPLICATIONS. MEDIUM OR LIGHT ADHESIVE MASKING OR WRAP LABEL TAPE IS RECOMMENDED IF TAPE IS USED. ANY TAPE LEFT ON PAINTED SURFACE FOR EXTENDED PERIODS WILL BE DIFFICULT TO REMOVE. NEVER USE CLEAR OR SCOTCH TAPE FOR THESE APPLICATIONS.

- Read all safety and operating instructions before using this product.
- All safety and operating instructions should be retained for future reference.
- Obey all cautions in the operating instructions and on the back of the unit.
- All operating instructions should be followed.
- This product should not be used near water, i.e. a bathtub, sink, swimming pool, wet basement, etc.
- This product should be located so that its position does not interfere with its proper ventilation. It should not be placed flat against a wall or placed in a built-in enclosure that will impede the flow of cooling air.
- This product should not be placed near a source of heat such as a stove, radiator or another heat producing amplifier.
- Connect only to a power supply of the type marked on the unit adjacent to the power supply cord.
- Never break off the ground pin on the power supply cord. For more information on grounding write for our free booklet "Shock Hazard and Grounding".
- Power supply cords should always be handled carefully. Never walk or place equipment on power supply cords. Periodically check cords for cuts or signs of stress, especially at the plug and the point where the cord exits the unit.
- The power supply cord should be unplugged when the unit is to be stored for long periods of time.
- If this product is to be mounted in an equipment rack, rear support should be provided.
- Metel parts can be cleaned with a damp rag. The vinyl covering used on some units can be cleaned with a damp rag or an ammonia based household cleaner if necessary.
- Care should be taken so that objects do not fall and liquids are not spilled into the unit through the ventilation holes or any other openings.
- This unit should be checked by a qualified service technician if:
 - The power supply cord or plug has been damaged.
 - Anything has fallen or been spilled into the unit.
 - The unit does not operate correctly.
 - The unit has been dropped or the enclosure damaged.
- The user should not attempt to service this equipment. All service work should be done by a qualified service technician.

PEAVEY
ARCHITECTURAL ACOUSTICS®

Features and specifications subject to change without notice.

A DIVISION OF PEAVEY ELECTRONICS CORPORATION / 711 A Street / Meridian, MS 39302-2698/ U.S.A. / Telephone: (601) 483-5376 / Telex: 504115 / Fax: 484-4278