



INNOVATION. AMPLIFIED.™

Chapter 6

Standby.....For the Truth

**by
Hartley Peavey**

STANDBY..... FOR THE TRUTH

Incredibly, very few modern technicians (and even fewer players) understand why so-called “standby” switches have been placed on guitar amplifiers for many decades. Almost every player believes that the standby switch is provided on their amps to put the amp in “standby mode” while they take a break, so that when they flip the switch back on, the amp will be instantly playable. The truth is that’s NOT the original purpose of a standby switch. In order to fully understand the problems and virtues of utilizing a standby switch, one needs to understand a little about how vacuum tubes actually work. Knowledge about vacuum tubes was fairly widespread in the 30’s, 40’s and even in the 50’s; but since the advent of transistor amps (beginning in the early 60’s) much of the “in depth” knowledge about vacuum tubes has been “lost.”



Most people know that Thomas Edison invented the so-called “electric light bulb.” He discovered, after many thousands of “trial and error” experiments, that he could create light by heating a Tungsten filament to “incandescence” in a vacuum. If the vacuum were not present, the white hot filament would instantaneously vaporize by rapid combination with oxygen in the air. By eliminating the presence of oxygen, the Tungsten filament could be heated to the point that light was produced (incandescence) thus, creating the “light bulb.” Early light bulbs featured clear glass and were fairly reliable, but tended to suffer from a blackening effect on the inside of the glass bulb after a considerable number of hours of operation. Edison and his team tried many different methods to eliminate this internal “blackening” effect without a lot of success.

One of the methods tried was inserting a small metal electrode through the side of the glass bulb and connecting that electrode to a source of positive voltage. Much to the surprise of the Edison lab personnel, they



Light bulb with added Electrode

discovered that a current was flowing through the vacuum from the heated filament to the electrode in the side of the glass bulb. This phenomenon was named “the Edison Effect” and marked the discovery of what is generally known as “thermionic emission” (which is the operational basis of most vacuum tubes). This new two element “light bulb”/tube represented the first “RECTIFIER,” since it had only two elements (the filament/cathode and the positively charged plate/anode). Electrons were able to move through the vacuum from the negatively charged filament/cathode to the positively charged plate/anode. Please note, the flow of electrons (current) traveled in one direction; i.e., from cathode to anode, NOT vice versa. Thus, the “Vacuum Tube Rectifier” (diode) was born.

Once the so-called “Edison Effect” became widely known, laboratories all over the world began experimenting with light bulbs with secondary electrodes called anodes (or plates). Scientists on both sides of the Atlantic realized that if they could establish a one way flow of electrons, this phenomenon would be even more useful if some method could be devised to VARIABLY CONTROL the flow of electrons...In essence, to create a kind of “electronic valve.” Fleming (in the UK) and DeForest (in the US) apparently discovered (about the same time) that if a third element was added to the tube, the flow of electrons could be controlled by applying a variable negative voltage to this third element, which is usually called a “grid.” In the early 1900’s, DeForest filed a patent for a three element vacuum tube that he called the “Audion,” thus making possible amplification as we know it. The British called this device a “VALVE” since that’s what it DOES! The US called it a “TUBE,” since that’s what it LOOKED LIKE! Both names are “correct!”

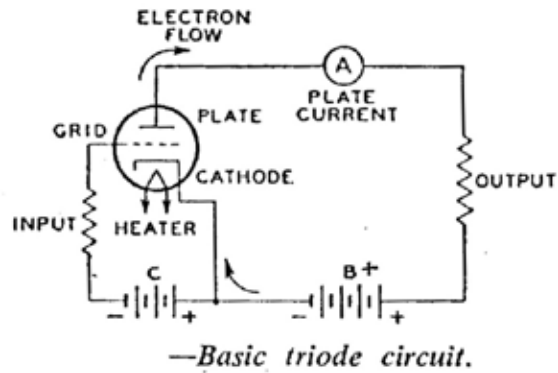
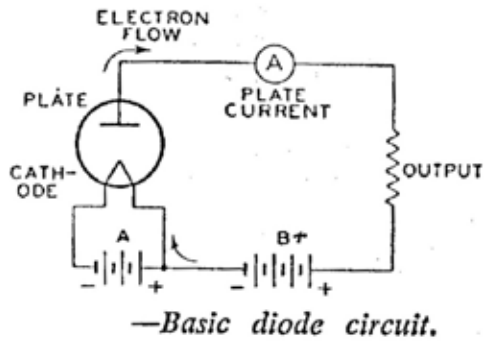

Since the discovery of the "Edison Effect" and the electronic valve (tube) much progress has been made in the tubes (valves) themselves, as well as the associated circuitry. The earliest use for audio amplification was in long distance telephony as "repeaters" for "longline" use. Obviously, audio amplifiers operate using "direct current" (DC) and a convenient means of converting the AC mains/line voltage to direct current was necessary. Above, we

discussed the fact that in a "two element" vacuum tube, current (i.e. the flow of electrons) flows just ONE WAY (from the negatively charged cathode to the positively charged anode) thus creating a vacuum tube diode that today we call a "RECTIFIER." Because of the unique characteristics of these tubes, they were almost universally used to convert AC to DC until the invention of the solid state diode many decades later.

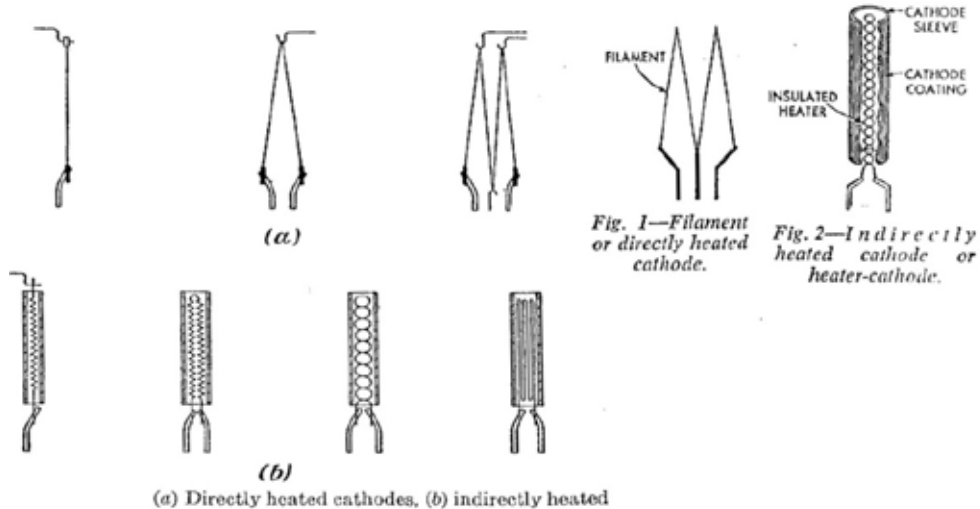
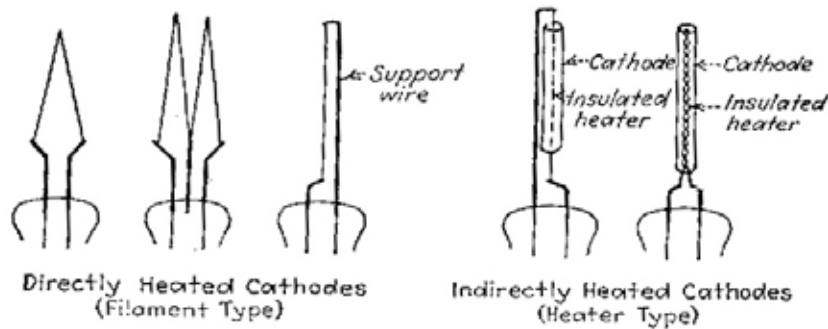

It is important to understand at least the basic process that occurs inside the vacuum tube when the cathode emits electrons. Before discussing tube/valve "mechanics," you should know that there are a number of different configurations of vacuum tube rectifiers. As far as audio amplifiers are concerned, we need be aware of just two basic types. The simplest

(and first) variety of vacuum tube rectifiers utilized so-called "directly heated cathodes." Essentially, these cathodes are merely modified versions of the Tungsten filaments themselves, having no additional structure other than the "heater" itself, usually being treated with some kind of "emissive" coating. The first heater cathodes were pure Tungsten, which

were less than “ideal” as a cathode. Further research into the chemistry of cathode materials produced a cathode that was treated with thorium, which reduced the optimum operating temperature by about 1,000 °F. Unfortunately, Thoriated Tungsten is extremely brittle and sensitive to shock; therefore, later research indicated that a tungsten filament coated with barium and/or strontium oxide, not only enabled substantially lower operating temperatures, but also increased emission of electrons. Later calcium carbonate was added to this coating to stabilize the tube’s operation by minimizing another internal problem to the tube called “secondary emission (which is another tube amp phenomenon beyond the scope of this paper).

The early rectifiers used “directly heated cathodes” (which were themselves, merely the heater filaments coated with a barium/strontium oxide). They produced output voltage VERY RAPIDLY when turned on. Since these directly heated cathodes were often used to power other tubes (valves) whose cathodes were “INDIRECTLY HEATED,” a problem arose when the full plate voltage (B+) was applied BEFORE the “indirectly heated” cathodes of the audio amplifier’s tubes reached their operating temperature. When the full high voltage (B+) is applied significantly BEFORE a tube reaches operating temperature, the cathode coating can be “stripped” of its ability to emit electrons. This destructive process is called “cathode stripping” and it is mainly for THIS REASON that so-called “standby” switches were provided on numerous electronic devices using DIRECTLY HEATED RECTIFIERS (with INDIRECTLY HEATED TUBES for operation)!

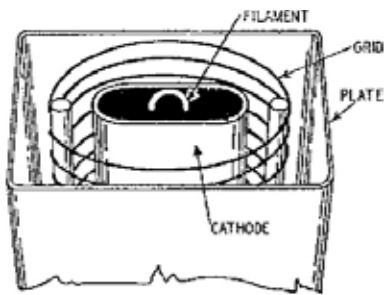

Physical structure of a triode.

Recognizing the problem with rectifiers that delivered the high B+ voltages almost instantaneously, tube designers developed numerous “INDIRECTLY HEATED” cathode rectifiers which delayed AVAILABILITY of full high voltage since the cathodes of these rectifiers often had relatively slow (controlled) warm up time. In audio amplification, the most popular indirectly heated

DIRECTLY HEATED CATHODES

INDIRECTLY HEATED CATHODES



cathode rectifier presently is the 5AR4/GZ34. This tube has a controlled warm up time especially designed to match the warm up time of the other indirectly heated cathode tubes in an amp. Fortunately, the 5AR4/GZ34 is readily available and (in most instances) can replace the venerable 5U4 and in some cases (where there’s adequate 3 amp heater current) the smaller (2 amp) 5Y3. An additional benefit of indirectly heated cathode rectifiers is that they are usually more efficient, while at the same time providing less voltage drop across the tube because of its more efficient design. Using these “controlled warm up tube” rectifiers, to a major degree, negates the need for a “standby” switch because their controlled warm up time accomplishes (more or less) the same thing (automatically) that a “standby switch” is SUPPOSED to do. Most modern audio amps using tube type rectifiers utilize (or should) a controlled warm up rectifier such as the 5AR4/GZ34.



ALTERNATING VOLTAGE APPLIED TO PLATES OF DIODES

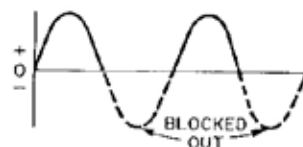

HALF-WAVE RECTIFIER PULSATING DIRECT CURRENT FLOWING THROUGH THE LOAD

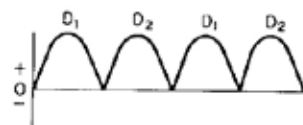

FULL-WAVE RECTIFIER PULSATING DIRECT CURRENT FLOWING THROUGH THE LOAD

INDIRECTLY HEATED CATHODE AUDIO AMPLIFIER TUBES



It should be noted that some amp designers and musicians prefer using the technically inferior direct heated cathode rectifiers because of their less efficient operation, as compared to more modern types such as the GZ34/5AR4 or the smaller GZ-81 indirectly heated cathode rectifiers. The older rectifiers, such as the 5Y3, 5U4, 5R4, etc, etc. have a higher voltage drop, resulting in less B+ and have a more pronounced tendency to “sag” under load. Some players and amp designers believe this is desirable for certain playing styles. The more modern tube rectifiers are more efficient, have less voltage drop, better regulation (less sag) as well as providing the tube longevity benefits of their controlled warm up. In spite of the above, you will sometimes see modern amplifiers designed with the cheaper and less efficient directly heated types of tube rectifiers such as the 5Y3 and 5U4. It is my opinion that if tube rectifiers are to be used, the more modern and efficient indirectly heated types are the FAR better choice (and in most cases provide a direct replacement). A word of caution is in order, the two amp heater rating of the 5Y3 has sometimes been a limitation in replacing that particular tube with the GZ34/5AR4, since the latter’s heater current requirements are the same as the larger (3 amp) 5U4.

Most musicians **WRONGLY** assume that the standby switch is provided primarily to disable the amplifier in such a way as to provide instantaneous operation by switching on the “standby” switch. Some even refer to this switch as a “beer button” to cut off the amp during breaks in a performance. Unfortunately, this very widely held **MISCONCEPTION** can (and does) cause problems. The nature of these problems should be understood if one wants to maintain optimum tube life and performance for as long as possible.

As stated above, standby switches have more or less become an “expected feature” of modern tube in-

strument amplifiers. In many cases, these so-called “standby” switches are provided only because they are “expected” to be there. One should always be aware that the **REAL** reason the standby switch is provided is to switch OFF the high voltage (B+) UNTIL the tubes reach their **FULL OPERATING TEMPERATURE**, so as to avoid “cathode stripping” of the indirectly heated cathodes of the preamp and output tubes.

Peavey provides an “**AUTOMATIC STANDBY FEATURE**” on most of its tube amps through the use of what are called “inrush current limiters.” These are devices having a “reverse temperature coefficient,” i.e. they have substantial resistance when **COLD** and almost no resistance after they **WARM UP!** When these devices are inserted into the power supply, they present a resistance to the “inrush” of current to the power supply, thus considerably **SLOWING** down the “warm up” process and allowing the tubes to reach their operating temperature **BEFORE** the full high voltage (B+) is applied to the plates. This can be thought of as a kind of “automatic standby switch.” Most Peavey tube amps utilize these “inrush current limiters” (whether the amp features a standby switch or not). We do that as a safety factor simply because most players have no idea what the standby switch is actually for. Hopefully, the above sheds some light on the real purpose and proper use of the standby switch

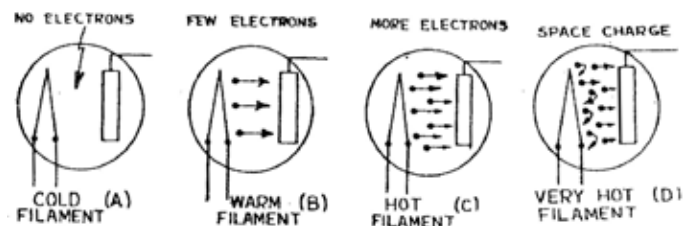

Above, we mentioned the concept of “cathode stripping,” which can occur when the full high voltage supply is applied to the anode (plate) of a tube **BEFORE** its heater/cathode reaches normal operating temperature. The mechanism that causes this is often not understood, but any tube amp user should be aware that electrons are emitted from the cathode in basically a “two step” process. As the cathode is heated to incandescence (i.e. turns red) a small “cloud” of electrons develops around the cathode itself. These electrons literally “boil” off the cathode material into the space around it, and this is known as “space charge.” Ideally, electrons are attracted to the anode (plate) from this “cloud,” as opposed to directly from the cathode material itself. When the cathode has not reached its proper

operating temperature (i.e. the cathode is not yet incandescent/glowing) electrons are “ripped” from the barium/strontium/calcium carbonate cathode coating itself, causing a phenomenon known as “cathode stripping.” The standby switch was provided to allow the tubes to reach their full operating temperature (thus, establishing the “space charge” around the cathode) BEFORE the high voltage is applied to the plates.

While the above is fairly simple and basic explanation, one should also be aware that EXCESSIVE USE of a standby switch can cause another destructive process within the tube. If the tubes in the amp are allowed to operate for considerable lengths of time with the standby switch off (no B+/high voltage) the cathode material itself tends to build up a destructive process within itself, and this is referred to as “cathode poisoning.” The “old timers” used to call this phenomenon “SLEEPING SICKNESS!” When a tube is at full operating temperature and no current is being drawn (as is the case with no B+/high voltage) a high resistance layer is gradually formed at the “interface” between the oxide coating and the nickel cathode structure. This layer of barium orthosilicate causes tube performance to degrade significantly. It is important that the standby switch NOT be left in the “off position” (no B+) for more than 15 to 20 minutes at a time to avoid “poisoning” the tube’s cathodes.

Ideally (in the standby mode) a tube should be operated with REDUCED heater current AND REDUCED plate voltage (instead of FULL heater current and NO plate voltage). I know of no instrument amp that has ever used this expensive technique.

In addition to the current inrush limiters, Peavey utilizes a somewhat different approach to standby operation. The inrush current limiters help protect the amplifier at turn on (cold start) but conventional standby switches (that remove the B+ from the plates) can cause poisoning of the cathode, which can rapidly damage tube performance. We have found that disabling voltage to the screen grids of the output tubes effectively shuts the tube operation down to a major degree yet (by retaining full voltage on the plates) allows current to continue to flow albeit at a greatly reduced rate. This “standby” technique effectively prevents so-called “sleeping sickness”/cathode.

poisoning if the standby switch is accidentally left on for an extended period. This method also reduces stress and arcing in the standby switch itself because of the reduced current draw of the screens of the tubes/valves.

Given that the true purpose of a standby switch is generally not understood, and the fact that the improper operation of the standby switch can cause problems when EITHER ON or OFF, I feel it is vital that the player understand the true purpose of a standby switch. However, the player also needs to understand the problems that can occur when the standby switch is used improperly, causing the aforementioned “cathode stripping” on one hand, and “cathode poisoning” on the other hand, both of which can (and often do) cause tubes to fail prematurely.

Even though it is “counterintuitive,” ideally the standby switch should be eliminated through the use of some kind of AUTOMATIC device that slows up the turn on process and allows the tube heaters and the associated cathodes to reach full operating temperature BEFORE the full high voltage (B+) is applied. We have found that “inrush current limiters” operate perfectly in this role, have no moving parts, and thus very effectively optimize tube life in an amplifier. This is why Peavey uses “inrush current limiters” in most of its tube amps (whether a standby switch is incorporated or not). These devices can be considered “automatic standby switches,” providing the maximum protection to the tubes. Almost as good is the usage of controlled warm up rectifiers such as the 5AR4/GZ34.

Hopefully the above will “shed some light” on the single most misunderstood feature of tube guitar amps. More information about this is available on Peavey’s website and on “PVTV.”

Lined writing area consisting of 30 horizontal lines.



INNOVATION. AMPLIFIED.™

Peavey Electronics Corporation • 5022 Hartley Peavey Drive • Meridian, MS 39305
Phone: (601) 483-5365 • Fax: (601) 486-1278 • www.peavey.com • ©2006 Printed in the U.S.A.