



Unity[®] 4 Compact Mixer

Operating Manual





FCC/ICES Compliancy Statement

This device complies with Part 15 of the FCC rules and Industry Canada license-exempt RSS Standard(s). Operation is subject to the following two conditions: (1) this device may not cause harmful interference, and (2) this device must accept any interference received, that may cause undesired operation.

Le présent appareil est conforme aux CNR d'Industrie Canada applicables aux appareils radio exempts de licence. L'exploitation est autorisée aux deux conditions suivantes: (1) l'appareil ne doit pas produire de brouillage, et (2) l'utilisateur de l'appareil doit accepter tout brouillage radioélectrique subi, même si le brouillage est susceptible d'en compromettre le fonctionnement.

Warning: Changes or modifications to the equipment not approved by Peavey Electronics Corp. can void the user's authority to use the equipment.

Note – This equipment has been tested and found to comply with the limits for a Class B digital device, pursuant to Part 15 of the FCC Rules. These limits are designed to provide reasonable protection against harmful interference in a residential installation. This equipment generates, uses, and can radiate radio frequency energy and, if not installed and used in accordance with the instructions, may cause harmful interference to radio communications. However, there is no guarantee that interference will not occur in a particular installation. If this equipment does cause harmful interference to radio or television reception, which can be determined by turning the equipment off and on, the user is encouraged to try and correct the interference by one or more of the following measures.

- Reorient or relocate the receiving antenna.
- Increase the separation between the equipment and receiver.
- Connect the equipment into an outlet on a circuit different from that to which the receiver is connected.
- Consult the dealer or an experienced radio/TV technician for help.

Caution

The equipment complies with FCC radiation exposure limits set forth for an uncontrolled environment.



Unity™ 4 Digital Mixer

Peavey brings you the Unity Digital Mixer Series, a powerful line of compact digital mixers designed to streamline your content-creation/podcasting workflow, elevate your production value, and put professional audio control right at your fingertips. Comprising the Unity 4, Unity 6, and Unity 8, this series is built specifically to manage the modern demands of streaming, recording, and live sound reinforcement. No matter where you are on your creative journey, the Unity series adapts to your setup so you can focus entirely on what you do best: creating great content.

The Shared DNA: Built for Streaming Perfection

Every mixer in the Unity lineup shares a core foundation of pro-grade features designed to solve your biggest audio headaches right out of the box:

- **Studio-Grade Foundation:** Every model is equipped with phantom power to unlock the true potential of ultra-detailed studio condenser microphones.
- **Built-In 2-Channel USB Interface:** Forget buying a separate audio interface. Plug a Unity mixer directly into your computer to seamlessly route stereo audio to and from your favorite recording or streaming software.
- **Echo-Free Mix-Minus:** Hosting a remote guest? Unity's hardware-level mix-minus ensures your remote callers hear you perfectly without suffering through a distracting, delayed echo of their own voice.
- **True Wireless Bluetooth Input:** Instantly pair your phone or tablet wirelessly to stream background music, take phone-in callers, or trigger sound clips on a dedicated Bluetooth input channel.
- **Hands-On EQ & Studio FX:** Ditch the CPU-hogging software plugins. Polish your voice or instruments instantly using tactile, hands-on control knobs.
- **Independent Headphone Mix:** Take complete control over your personal monitoring environment, tailoring exactly what you hear in your ears without affecting the mainstream mix.

The new Unity™ 4 Digital Mixer (SKU: 03622360) makes it easy to bring microphones, instruments, and music together in one simple place. Whether you're recording a podcast, streaming online, practicing at home, or running sound for a small event, Unity gives you clean sound and simple control without the learning curve. Plug in, turn it on, and get to work.

Features

USB-C Computer Audio Interface

Phantom Power for Studio Microphones

Bluetooth Audio In

Remote Guest Integration

Studio Quality EQ and FXs



CAUTION: Hot Surface. Do Not Touch.

ATTENTION: Surface chaude. Ne pas toucher

Unity 4 Front Panel

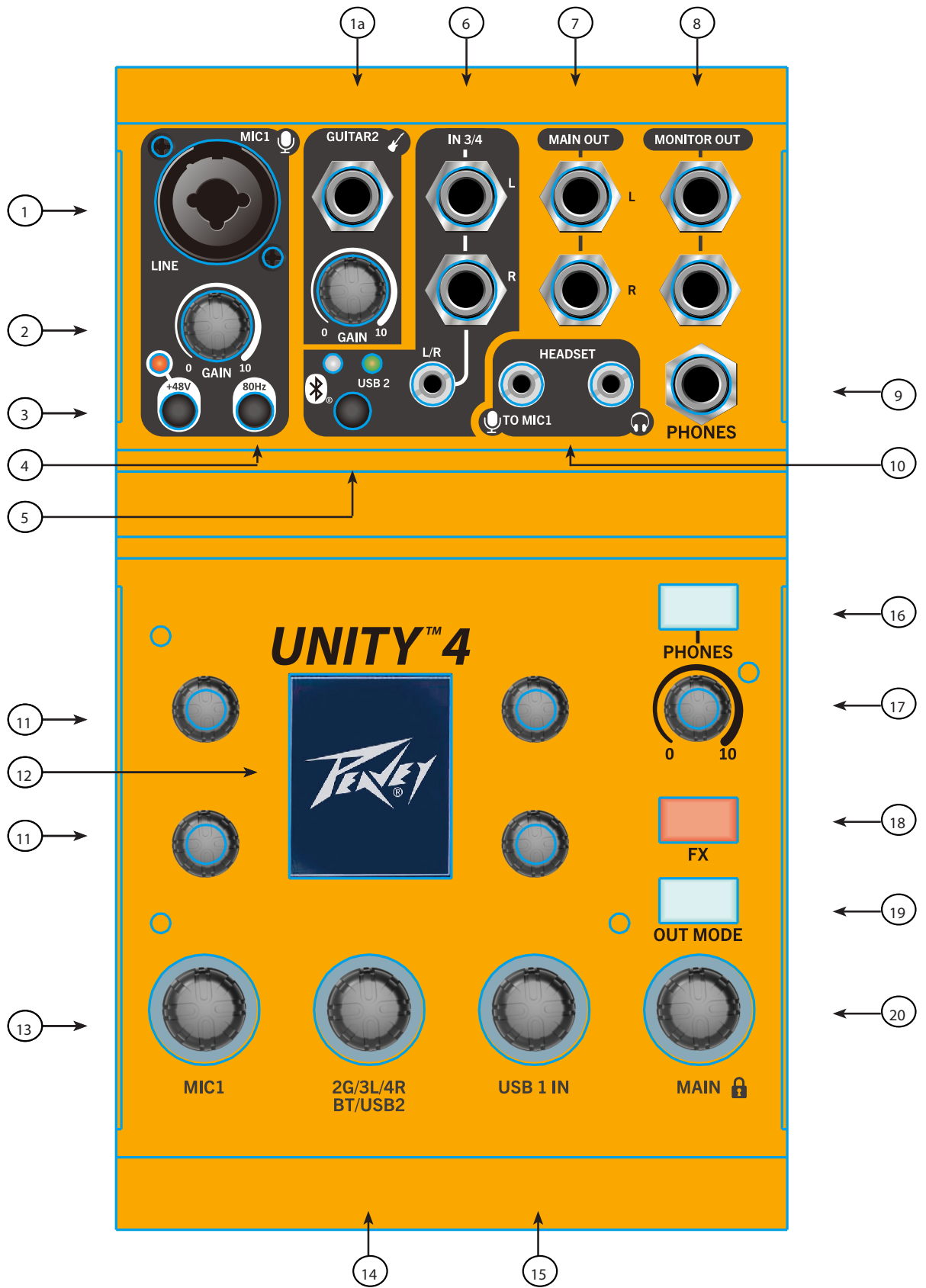

Unity 4 Front Panel

1) Mic/Line Input

This combination input jack accepts a ¼" or XLR balanced plug. The XLR balanced input is optimized for a microphone or other low impedance source. The ¼" input is a TRS balanced type, and also accepts ordinary TS guitar cables.

1a) Guitar Input

This 1/4" input accepts signal from a guitar.

2) Gain Controls

The Input Gain control is used to establish proper gain structure in the channel. The input gain can be adjusted over a wide range to compensate for soft voices or very loud drums. To maximize the signal-to-noise ratio, the gain control should be set to the proper level, with the MIC1 Level Knob (13) set to 80%.

3) Phantom Power

This Switch applies +48 VDC voltage to the input XLR connectors to power microphones requiring phantom power.

4) 80 Hz HI PASS FILTER

The hi pass filter has a corner frequency of 80 Hz. When engaged, it can improve clarity by removing low frequencies that make a mix sound muddy. This feature is especially useful when playing outside on a windy day or on a hollow-sounding, noisy stage. These kinds of ambient noises can rob your sound system of power. Engaging this switch will remove those frequencies from the system and restore power where needed.

5) BLUETOOTH/USB2 SWITCH

This switch is only active when a USB signal is connected to the USB2 (4) connector. Once that connection is active, this switch can be used to select between the BT audio stream and the USB2 audio stream. Only one of those two signals can be sent to channel 2 at a time.

6) Stereo Media Inputs 3/4

The 3.5mm input accepts a stereo input from the output of an MP3 player, CD player, tape deck or other similar device. This input is optimized for line inputs and portable handheld devices. STEREO 1/4" INPUTS are also available.

7) 1/4" STEREO MAIN OUTPUTS

These are the main stereo outputs. These TRS electronically balanced outputs carry the main mix signal.

8) Monitor Out

These monitor outputs are TRS electronically balanced and allow the headphone signal to be sent to an external amplifier or powered speaker for monitoring.

9) Headphone Jack

1/4" jack for connecting headphone for monitoring the 1/2 dry or the main output mix. The source is selected by the 1/2 button. The default is the main mix. If the button is pressed and glowing blue, the dry Mic1/Gtr2 signal will be heard in the headphones.

10) Headset Connections

Input: When the microphone plug (normally pink) of your headset is connected to the headset input jack, the signal is routed to the MIC 1 (channel 1) input.

Output: When the headset headphone jack (normally light green) of your headset is plugged to the headset output jack, the sound will be the same as the main headphone jack (9). The level can be adjusted with the headphone level control (17).

11) Parameter Controls

These four encoders can be used to navigate the channel edit screens. The control must be turned to change the setting and pushed to select the setting. The editing of the EQ and EFX is explained in the EQ/EFX editing section of the manual.

12) LCD Display (Meters/Edit)

The LCD display serves two main functions, the default function is a meter array that shows the signal level of all of the input channels and the main L/R outputs. When any of the channel or main level controls are turned, the screen will show the position of the corresponding level control. If the mixer is placed in the edit mode, the screen is used in conjunction with the 4 parameter knobs (11) to make adjustments to the channel EQ/EFX settings or to edit the USB outputs settings. It also displays BT or USB connectivity as well as the mixer's firmware version.

13) Mic1 Level Control

The MIC1 level control is to adjust the amount of channel 1 signal level in the main mix. This control can be adjusted from 0 to 99%. The unity gain position is 80% and that is a good starting place to set the control. This control is also used to mute the signal in channel 1 and to edit the EQ and EFX settings in channel 1. A long press of this control will mute the channel 1 signal. If the channel is muted, the ring around the control will glow red. A short press will enter the channel edit screen. While in the edit mode, the ring around the control will flash red.

14) 2G/3L/4R/BT/USB2 Level Control

This level control is used to adjust the combined signal of channel 2 to the main mix. This channel will include the 2Guitar – 3L/4R – BT or USB2 signals. The BT or USB2 signal will be chosen by the BT/USB2 switch (5). This control can be adjusted from 0 to 99%. The unity gain position is 80% and that is a good starting place to set the control. It is also used to mute the signal in channel 2 and to edit the EQ and EFX settings in channel 2. A long press of this control will mute the channel 2 signal. If the channel is muted, the ring around the control will glow red. A short press will enter the channel edit screen. While in the edit mode, the ring around the control will flash red.

15) USB1 Level Control

This level control is used to adjust the amount of channel 3 signal in the main mix. This control can be adjusted from 0 to 99%. The unity gain position is 80% and that is a good starting place to set the control. This control is also used to mute the signal in channel 3 and to edit the EQ settings in channel 3. A long press of this control will mute the channel 3 signal. If the channel is muted, the ring around the control will glow red. A short press will enter the channel edit screen. While in the edit mode, the ring around the control will flash red.

16) ½ HEADPHONE MODE

Pressing the ½ button sends the dry signals of MIC1 and Guitar2 to the headphones. When in this mode, the button will glow blue. When the button is in the “off” position, the main mix will be sent to the headphones and the blue backlight will be turned off.

17) HEADPHONE LEVEL CONTROL

Turning this level control to the right increases the volume of the headphone signal. Turning it left turns the headphone volume down.

18) FX MUTE

Pressing this button will mute the EFX selected for channels 1 and 2. While muted, the button will glow red. If the button is not lit, the EFX are active.

19) USB Out Mode

Pressing the USB Out Mode button allows the user to edit the USB1 and USB2 output signals. Once the button is pressed and the button is blinking, the USB settings can be edited on the main edit screen. On the screen, the levels of USB1 and USB2 out can be adjusted by the top two encoders. They are adjustable from 0 to 99%, 80% is a unity gain and a good starting setting. While in the edit screen, the signal being sent to USB1 and USB2 can be edited with the bottom two encoders. You can select from the Main mix, the Loop and the Dry 1L/2R signal.

20) MAIN LEVEL CONTROL

Turning this level control increases and decreases the amount of total signal in the main outputs. Turning it to the right increases the amount of signal and turning it left decreases the amount of signal. It is adjustable from 0 to 99%, 80% is unity gain and a good starting setting. This encoder is also used as a global lock and a global signal mute. A short press lock's all of the mixers controls. Once locked, only the mic input gain and the headphone volume will work. When locked, the ring around the control will flash red and a lock symbol will be seen on the LCD screen. Another short press will unlock the controls. A long press of this control will mute the main outputs. When activated, the ring around the control will glow red. Another long press will unmute the signal and the light will go out.

Unity 4 Rear Panel

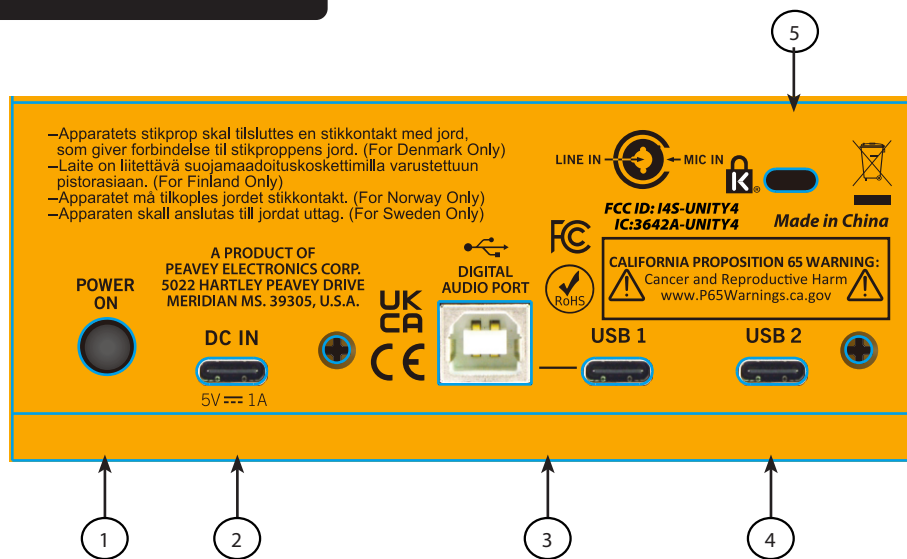

1) Power Button

This is the main power switch. Pressing this button turns the unit on.

2) DC Input

Connect the included power supply here. Use a 5V DC, 1 A adapter only. Replace only with Peavey part number 30909411.

3) Digital Audio Port/USB 1 Port

The USB-B or USB-C connectors are used to connect the Unity 4 mixer to a computer for recording or playing back digital audio to/from your computer. The USB ports sends the mixer's main, loop or dry 1/2 signals out to the computer. The level and sources can be adjusted by pressing the USB out mode button (19). USB 1 input signal level is controlled by adjusting the USB1 level knob (15). Only use one connector at a time.

4) USB 2 Port

The USB-C connector is used to connect the Unity 4 mixer to a computer for recording or playing back digital audio to/from your computer. The USB port sends the mixer's main, loop or dry 1/2 signals out to the computer. The level and sources can be adjusted by pressing the USB out mode button (19). USB 2 input signal level is controlled by adjusting the BT/USB2 level knob (14).

5) Kensington Lock

The Unity mixer can be used with a standard Kensington compatible lock can be used to secure your mixer and prevent theft.

How To Edit Channel Settings

To make changes to the channel EQ, start by short pressing the level control (13-15) of the channel you want to change. The ring around the encoder will blink red while in the edit mode. If no changes are made, it will automatically exit the edit mode after 15 seconds.

Once you enter the edit screen, it will look like this:



If you want to make changes to the channel EQ, press the parameter encoder (11) to the left of the box labeled EQ:

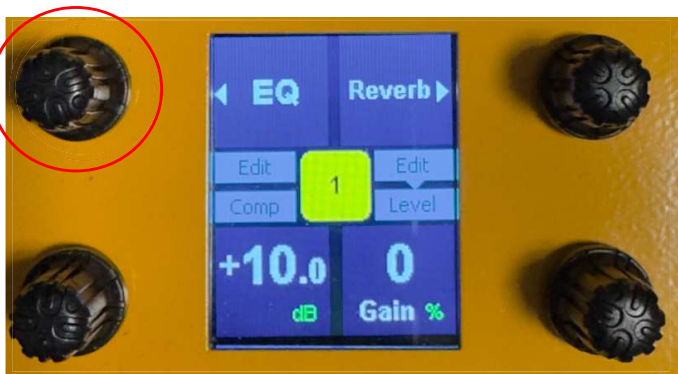

Once pressed, the screen will change to the edit screen:

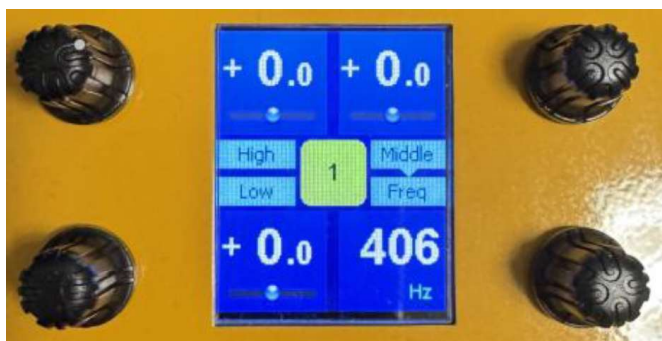

To make changes to the EQ, simply turn the encoder next to the parameter you want to change. For example, if you want to increase the high frequency response, simply turn the encoder next to the box labeled "high". The numbers will increment/decrement according to your changes.

To exit the edit mode, simply avoid touching any control for 15 seconds, or quickly press the channel level control (13-15) of the channel you want to control.

To change the FX settings for a particular channel, start the same way you would to enter the EQ edit screen, by short pressing the channel level control (13-15) of the channel you want to change.

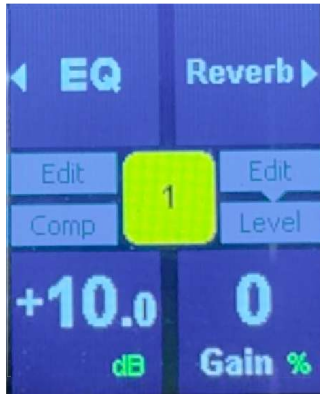

USING THE COMPRESSOR

Each channel has an onboard compressor that is always in circuit. The lower left encoder is used to adjust the threshold from -80dB to +10dB. Turning it to the left lowers the threshold and turning it to the right raises the compressor threshold. At +10dB the compressor is off, for all practical purposes. The compressor threshold can help you decide how much of the signal is controlled. For vocals or speech, a lower threshold can smooth out level changes. For instruments or a more dynamic sound, a higher threshold allows more expression while keeping peaks in check.

EDIT FX

To change the FX, turn the parameter encoder (11) next to the box with the currently selected effect displayed on the screen:

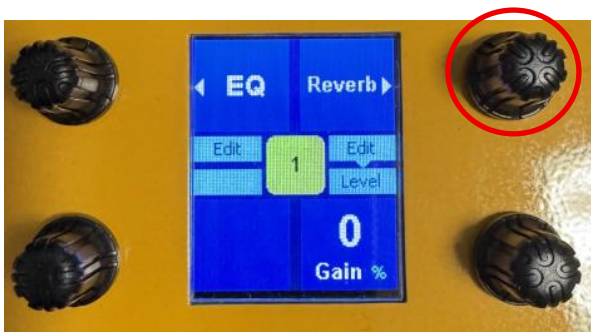

Turning the parameter encoder will scroll through the available effects for that channel. The available effects vary from channel to channel.

Channel 1: Reverb, Reverb+Delay, Delay or Plate

Channel 2: Reverb, Reverb+Delay, Delay, Plate, Plate+Chorus or Chorus.

Once an effect has been selected, you may want to adjust the level of the effect. That can be done on the same screen. The effect level is adjustable from 0 to 99% and can be changed by turning the parameter encoder to the right of the box labeled "Gain".

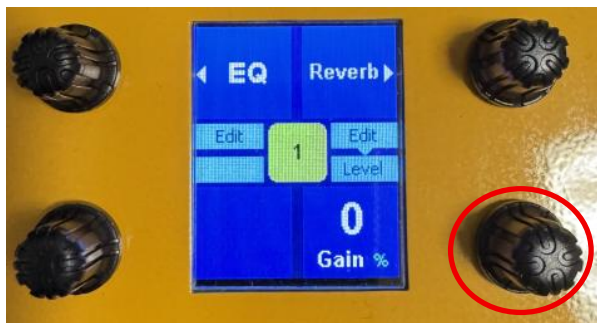

To edit an effect, press the parameter encoder next to the box with the effect name:



Once this button is pressed, the mixer will enter the effects edit screen:

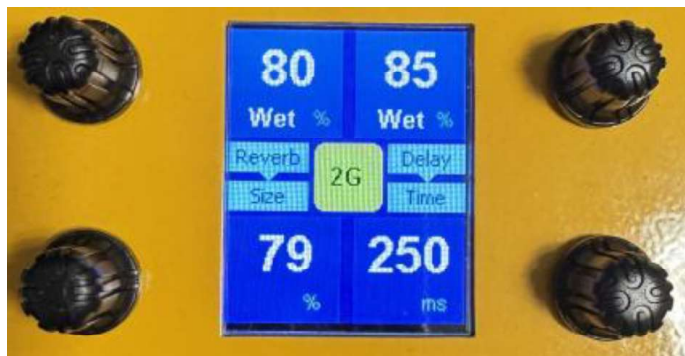

The settings can be adjusted by turning the encoder associated with the parameter displayed on the screen.

HOW TO CONNECT BLUETOOTH

The Bluetooth connection can be made by first opening the Bluetooth settings on your device. Make sure Bluetooth is turned on in your device. The Bluetooth connection from the mixer is always available and will be displayed as Unity 4 on the connecting device. Once you see the Unity 4 mixer on your device, simply tap the name and it should connect automatically. Once the connection is made, the Bluetooth logo will appear at the upper right corner of the display and the Bluetooth LED will glow continuously.

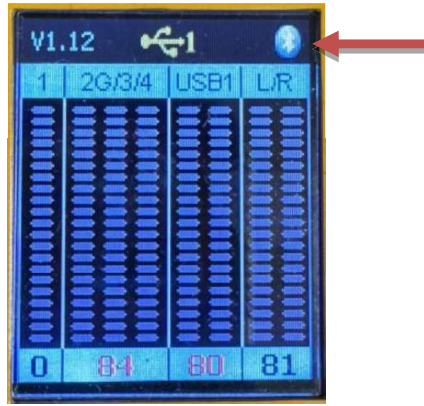

HOW TO RESTORE FACTORY SETTINGS

After pressing the power switch, press the FX MUTE+USB MODE buttons on the panel at the same time while the Peavey Logo is being displayed. The LCD will change to show "Factory Preset". Once "Factory Preset" is displayed, the mixer has been set to factory settings and will reboot.



HOW TO UPDATE FIRMWARE

After pressing the power switch, press the 1/2+FX MUTE buttons on the panel at the same time while the Peavey Logo is being displayed. The LCD will change to show "Firmware UPDATE". The mixer can now be connected to a PC through the USB1 USB-B port or USB-C port.



Once the mixer has successfully connected to the PC, the update software can be run. The firmware update must first be downloaded from the Peavey.com website. Once downloaded, it can be run by double clicking on the program. Once the program opens and the mixer is connected, press the Start Program button. The progress bar will display across the bottom of the window. Once the program is finished, press the OK button and the mixer will restart. The mixer will now be updated and ready to use.

Unity 4 Specifications

Input Connections:

MIC/LINE (mono)	Combo female XLR/ 1/4" jack	Balanced or unbalanced.
Guitar (mono)	1/4" phone jack	Balanced or unbalanced.
Line 3/4 (stereo)	1/4" phone jacks, 3.5mm	Balanced or unbalanced.
Mic Headset (mono)	3.5mm jack	
USB 1-2 (stereo)	USB-B and USB-C	
Bluetooth (stereo)	V5.0	

Output Connections:

Main Out (stereo)	1/4" phone jacks	Balanced or unbalanced.
Monitor Out (mono)	1/4" phone jack	Balanced or unbalanced.
Headphone Out (stereo)	1/4" phone jack	Unbalanced
Headset Out (stereo)	3.5mm jack	Unbalanced
USB 1-2 (stereo)	USB-B and USB-C	

Channel Function:

Mic1: Low-cut, Noise gate, Compressor, 3-band EQ, EFX's, Volume, Mute
Guitar: Noise gate, Compressor, 3-band EQ, EFX's, Volume, Mute
Line 3/4: Noise gate, 3-band EQ, EFX's, Volume, Mute
USB 1-2: 3-band EQ, Volume, Mute

Nominal Frequency Response:

+0, -1 dB from 10 Hz to 23 kHz

Hum and Noise:

< -90 dBu

Phantom Power Voltage:

+48 V DC

Power requirements:

5V DC, 1 Amp

Dimensions (W x D x H)

5.375 in. x 8.25 in. x 2.75 in.

137 mm x 210 mm x 70 mm

Net Weight:

1.75 lbs. (0.8 kg)

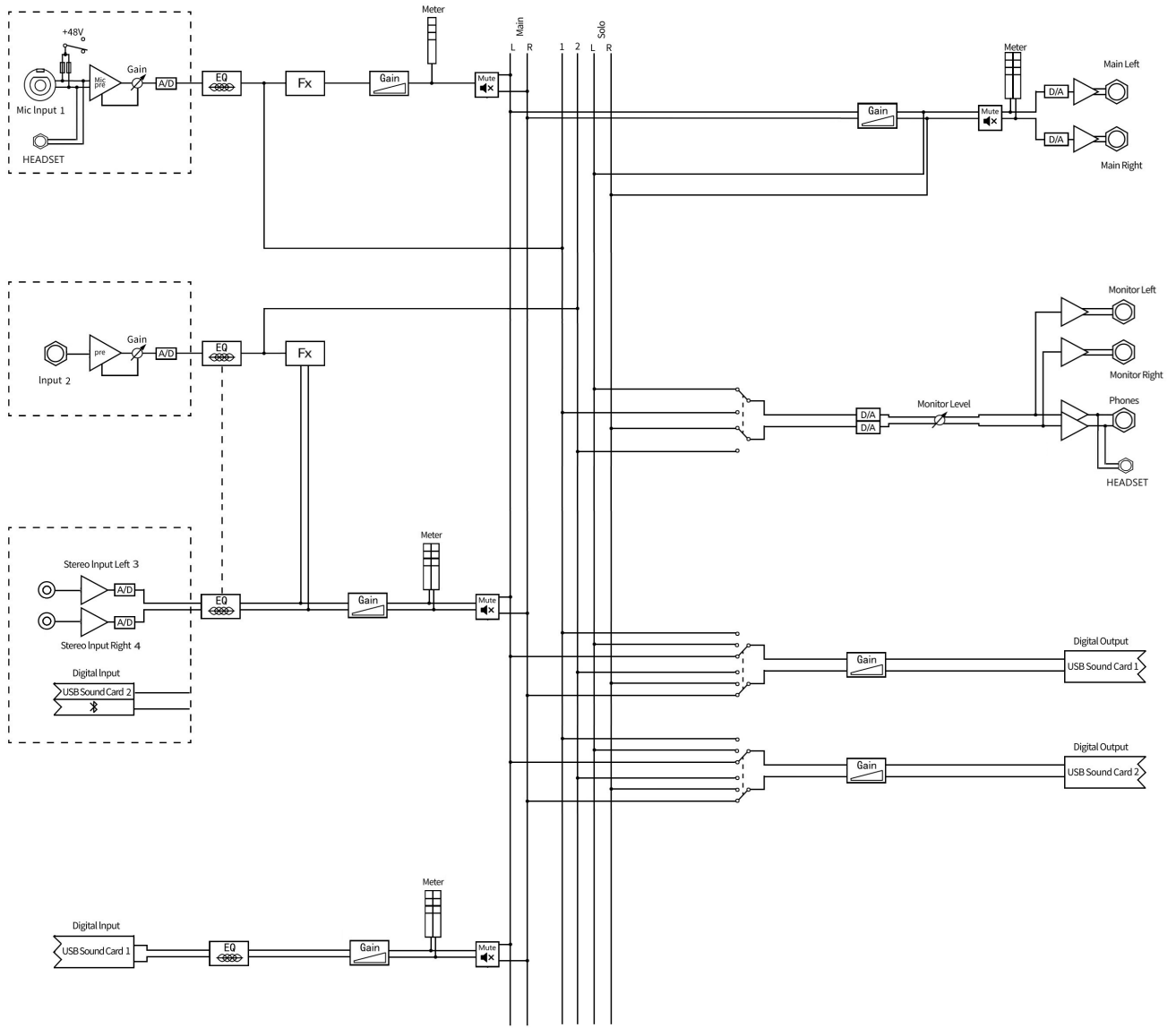



www.peavey.com

Warranty registration and information for U.S. customers available online at
www.peavey.com/warranty
or use the QR tag below



Features and specifications subject to change without notice.

Peavey Electronics Corporation 5022 Hartley Peavey Drive Meridian, MS 39305 (601) 483-5365 FAX (601) 486-1278



Logo referenced in Directive 2002/96/EC Annex IV
(OJ(L)37/38, 13.02.03 and defined in EN 50419: 2005
The bar is the symbol for marking of new waste and
is applied only to equipment manufactured after
13 August 2005